

PENTAX | W-800

A TRULY INTEGRATED SYSTEM

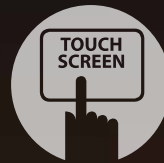

80th
PENTAX
SURVEYING
SINCE 1933
TI Asahi Co., Ltd.
anniversary

PENTAX

W-800

SIMPLE OPERATION
MODULAR SOFTWARE



Long Range
Extended EDM Performance

Ergonomic grip



Large easy to use
Color graphical
touch display,
alphanumeric
keyboard



CF-Card slot

Triple axis
compensator on
the W-821NX (1"),
the W-822NX (2")
and W-823NX (3")
models



Auto Focus



Standard
Ni-MH Battery



Advanced connectivity
USB, SD-Card slot,
RS-232C Data port

Incorporated
date clock



PENTAX | W-800 OUTSTANDING FEATURES

W-800 BENEFITS

- Customization is now a breeze
- Modular software upgrading path grows with you and your applications
- From Entry Level: for the occasional user to the more demanding survey tasks of the advanced users



PENTAX SOLUTION PARTNER

MANY SURVEY CHALLENGES, ONE LOGICAL SOLUTION: OPEN PLATFORM

By collaborating with selected Software Solution Partner, MicroSurvey, Pentax can offer a broad range of functionalities to cover almost every specific task.



EXTENDED EDM PERFORMANCE

Measures distances in reflectorless mode over 550m and over 7000m to a single prism while maintaining the same high level of accuracy.

Benefits: Its extended measuring range prevents you of making additional instrument setups.



PENTAX'S EXCLUSIVE AUTO FOCUS SYSTEM

Benefits: Always an instant razor sharp image.



MORE FLEXIBILITY FASTER TURNAROUND

Connectivity: In its standard configuration, the Pentax W-800 is equipped with multiple data-interfaces (mini-USB data port, CF-card slot and SD-card slot, RS-232C data port) providing seamless data-transfer to a PC or laptop for further data processing.



TRI-AXIS CORRECTION

The W-821NX, W-822NX and W-823NX models feature a unique precision Tri-axis correction to provide automatic error compensation, in addition to dual-axis correction. The error occurs where the vertical, horizontal and sight axis intersect.



PENTAX W-800 Series Technical Specifications

Model	W-800	W-821NX	W-822NX	W-823NX	W-825NX	W-835NX
Telescope	Magnification	30 x				
	Effective aperture	45 mm (EDM 45 mm)				
	Resolving power	3.0"				
	Field of view	2.6 % (1°30')				
	Minimum focus	1.0 m				
	Focus	Auto focus / Power focus / Manual				
Distance measurement	Laser class	Visible laser: Class III a (3R) (Reflectorless) / Class II (2) (Prism, sheet)				
Measurement range (Good conditions) (*3)	Reflectorless (*1)	1.5 ~ 550 m				
	Reflector sheet (*2)	1.5 ~ 600 m (800 m)				
	Mini prism	1.5 ~ 2500 m (3000 m)				
	1P	1.5 ~ 7000 m (9000 m)				
	3P	1.5 ~ 9000 m (9999 m)				
Accuracy (*4)	Prism / Reflector sheet	± (2 + 2 ppm x D) mm				
	Reflectorless	1.5m ~ 150m : ±(3+2ppm x D)mm / 150m ~ : ±(5+2ppm x D)mm / 300m ~ : ±(7+10ppm x D)mm				
	At Auto-ATM. Correction					
	Prism / Reflector sheet	± (2 + 10 ppm x D) mm				
	Reflectorless	1.5 ~ 300 m : ± (5 + 10 ppm x D) mm / 300 m ~ : ± (7 + 18 ppm x D) mm				
Measuring time (*5)	Repeat meas.	Normal (1 mm)	Prism / Reflector sheet 2.0 sec - Reflectorless 2.0 sec			
		Quick (1 mm)	Prism / Reflector sheet 1.2 sec (*6)			
	Initial meas.	Normal (10 mm)	Prism / Reflector sheet 0.4 sec - Reflectorless 0.4 sec			
		Normal (1 mm)	Prism / Reflector sheet 2.5 sec - Reflectorless 2.4 sec			
		Quick (1 mm)	Prism / Reflector sheet 1.7 sec (*6)			
Angle measurement	Measurement method	Absolute rotary encoder				
	Detection method	Vertical / horizontal angle: 2 sides				
	Minimum count	0.5"/1"/5" selectable				
	Accuracy (ISO 17123-3)	1"	2"	3"	5"	
Compensator	Axis	3 Axis (*7)			2 Axis	
	Range	± 3'				
Target screw		2 speed			1 speed	
Sensitivity of vials	Plate level (electronic)	30" / 1 div.				
	Circular level	8' / 2 mm				
Laser Plummet		Visible laser: ± 0.5mm (instrument height: 1.5m) (Optical Plummet is optional)				
Base		Detachable				Shifting
Dust & water resistance		IP54 (instrument only)				
Ambient temperature		-20°C ~ +50°C / -4°F ~ 122°F (working range)				
Tripod thread		5/8" x 11				35 mm P2
Dimensions / Weight	Dimensions	197 (W) x 347 (H) x 217 (L) mm				
	Weight (incl. battery)	6.3 kg				
	Carrying case	380 (W) x 292 (H) x 475 (L) mm / 3.2 kg				
Battery pack BP02	Power source	Ni-MH 4300 mAh (rechargeable) DC 6.0 V				
	Operation time	Approx. 5.5 hrs (ETH+EDM / Single Reflectorless measurement every 60 seconds)				
	Weight	380 g				
Battery charger BC03 and AC adapter AC01	Input Voltage (AC01)	AC 100 ~ 240 V				
	Output Voltage (BC03)	DC 7.5 V				
	Weight	280 g				
Data Process	CPU, Clock frequency	Intel® - XScale, 400 MHz				
	OS	Microsoft® - Windows® CE 4.2				
	Application software	Selectable				
	Internal memory	SDRAM = 64 MB / FLASH = 128MB (built-in)				
	Memory card	2GB (Max) (*8)				
	I / F	RS-232C or Bluetooth(Optional), CF Type II, SD CARD, USB				
Display / keyboard	Display type	3.7 inch - Color LCD, 640 x 480 pixels (*9) with back light and touch panel function				
	Quantity	2			1 (2nd optional)	
	Keys	33 each (12 numeric / 11 function / 10 special)				
	Display back light	Intensity settings: 10 steps				
Laser Pointer		Yes				
Date clock		Yes				

*1 The measurement range and accuracy of reflectorless, and time required to measure may vary by the shape, size of surface area and reflection rate of the target and its environment. The measurement range of reflectorless is determined by the white side of the Kodak Gray Card.

*2 Reflector sheet: PENTAX genuine Reflector sheet

*3 The measurement range may vary by conditions of the environment. Normal conditions: 20 km visibility with slight shimmer. Good conditions: 40 km visibility, overcast, no heat, no shimmer and moderate wind.

*4 When automatic atmospheric correction is on, the EDM error is 10 ppm in prism and reflector sheet mode.

Remarks: 1) Microsoft and Windows are a trademark or a registered trademark of Microsoft Corporation in the United States and other countries.
2) Intel is a registered trademark of Intel Corporation in the United States and other countries.

*5 EDM measuring time is determined in good conditions. It may take longer than usual to measure the distance exceeding 4000 m in prism mode and 300 m in reflectorless mode.

*6 Quick mode, which functions with prism and reflector sheet, is effective only under normal mode (1 mm) and up to 500 m.

*7 In addition to dual-axis correction in the (X) and (Y) direction, mechanical error in the instrument is corrected.

*8 Memory card is not supplied with the instrument.

*9 Depending on application software.

You should be able to use any SD card in your camera. While Pentax does not guarantee compatibility with any particular manufacturer or model, we have seen consistent compatibility with SD cards from Panasonic (1GB, 2GB), SanDisk (1GB, 2GB), and Toshiba (1GB, 2GB)

Ti Asahi Co., Ltd.
International Sales Department
 4-3-4 Ueno Iwatsuki-Ku, Saitama-Shi
 Saitama, 339-0073 Japan
 Tel.: +81-48-793-0118
 Fax: +81-48-793-0128
 E-mail: International@tiasahi.com
 www.pentaxsurveying.com/en/

Visit the W-800 series at:
www.pentaxsurveying.com/en/

Your Official Pentax Dealer



The CE marking assures that this product complies with the requirements of the EC directive for safety.



DANGER
 LASER RADIATION - DO NOT STARE INTO BEAM OR VIEW DIRECTLY WITH OPTICAL INSTRUMENT INTO SUNLIGHT
 620-690 nm/4.75mW max.
 CLASS IIIa LASER PRODUCT
 Laserclass IIIa, conform FDA 21 CFR Ch. 1 § 1040

CAUTION
 LASER RADIATION - DO NOT STARE INTO BEAM
 620-690 nm/0.95mW max.
 CLASS II LASER PRODUCT
 Laserclass II, conform FDA 21 CFR Ch. 1 § 1040

JSIMA
 Japan Surveying Instruments Manufacturers' Association

Member symbol of the Japan Surveying Instruments Manufacturers' Association representing the high quality surveying products.

TOTAL STATION W-800 SERIES

BASIC INSTRUCTION MANUAL

W-821NX
W-822NX
W-823NX
W-825NX
W-835NX



TI Asahi Co., Ltd.

International Sales Department
4-3-4 Ueno Iwatsuki-Ku, Saitama-Shi
Saitama, 339-0073 Japan
Tel.: +81-48-793-0118
Fax. +81-48-793-0128
E-mail: International@tiasahi.com
www.pentaxsurveying.com/en/

PENTAX

Before using this product, be sure that you have thoroughly read and understood this instruction manual to ensure proper operation. After reading this manual, be sure to keep in a convenient place for easy reference.

This Basic Instruction Manual contains the basic operation procedures and precautions on W-800 series hardware.

W-800 series is an open platform product and you can enjoy variety of application software on it. Regarding the operations of application software, please refer to their respective manuals.

Copyright © 2012 TI Asahi Co.,Ltd.

TI Asahi Co.,Ltd. makes no warranty, expressed or implied, including but not limited to any implied warranties or merchantability or fitness for a particular purpose, regarding these materials and makes such materials available.

PRECAUTIONS REGARDING SAFETY

Safety Precautions (Must be followed)

The following items are intended to prevent possible injury to the user or other people and/or damage to the instrument before it occurs. These safety precautions are important to the safe operation of this product and should be observed at all times.

Distinctive displays

The following displays are used to distinguish precautions by the degree of injury or damage that may result if the precaution is ignored.



WARNING

Items indicated by this display are precautions which, if ignored, would result in serious injury.



CAUTION

Items indicated by this display are precautions which, if ignored, may result in injury or material.

- Here "injury" refers to injuries such as cuts, burns or electric shock the treatment of which will not likely require hospitalization or long-term attention.
- "Material damage" refers to damage to facilities, buildings, acquired data, etc.

Before using this product, be sure that you have thoroughly read and understood this instruction manual to ensure proper operation. After reading this manual, be sure to keep it in a convenient place for easy reference.

This instrument complies with the protection requirement for residential and commercial areas. If this instrument is used close to industrial areas or transmitters, the equipment can be influenced by electromagnetic fields.



WARNING

- ⚠ Do not stare into the laser beam directly as this may result in damage to your eyes. W-800 is a Class IIIa (3R) Laser product.
- ⚠ Do not look into the laser radiation aperture directly as this may result in damage to your eyes.
- ⚠ Never use the telescope to view intense light such as direct sunlight or sunlight reflected through a prism as this may result in loss of sight.
- ⚠ Do not disassemble, modify or repair this product as there a risk of laser radiation.
- ⚠ Do not aim the laser beam at a person as it is harmful to the eyes and body. Receive the examination treatment by the doctor when the eyesight or body trouble is doubted by any chance.

- Electro-Magnetic Compatibility (EMC): This instrument complies with the protection requirement for residential and commercial areas. If this instrument is used close to industrial areas or transmitters, the equipment can be influenced by electromagnetic fields.
- Do not use this product in a coal mine, in a location where there is coal dust, or near flammable material as there is a risk of explosion.
- Do not disassemble, modify or repair this product as there is a risk of fire, electric shock and burn injury. If you think the product requires repair, contact the retail outlet where you purchased it or an authorized repair site.
- Only use the battery charger intended for this product as the battery charger. Use of another battery charger entails a risk of fire or burn injury from the battery bursting into flames due to possible differences in voltage or polarity.
- Do not use a damaged electric cord plug or loose electric outlet when charging as there is a risk of fire or electric shock.
- Do not charge the battery while covered by clothes or similar item as there is a risk of fire if the clothes ignite.
- Do not use the battery or charger when wet as there is a risk of fire and burn injury due to short-circuit.
- To prevent making short-circuit when removing the battery and charger from the case and storing them, apply electrically resistant tape to the poles of the battery. Storing the battery and charger as it may result in fire or burn injury due to short-circuit.
- Do not throw the battery into fire or expose it to heat as there is a risk of injury if it explodes.



CAUTION

- ⚠ For your safety, perform the initial and periodical inspection as well as when the instrument is fixed and adjusted.
- ⚠ When the laser beam enters eyes, an unexpected accident might be caused by blink of eyes. Do not place the laser product at a height where its laser beam may hit the eyes of car drivers and pedestrians.
- ⚠ Do not place the laser product at a place where its laser beam may hit a reflecting object such as a mirror or a glass window. The reflection beam of the laser is also harmful to the human body.
- ⚠ When not performing measurement, cut off the power supply or shade the Objective lens with Objective cap to prevent the instrument emitting the laser beam.
- ⚠ Keep the laser product in the place where the person who does not have the product knowledge such as children does not touch by mistake.
- ⚠ Before disposing of the instrument, destroy its power supply mechanism to prevent it from emitting the laser beam.

- Do not remove the handgrip without good reason. If it does come off, be sure to attach it securely to the instrument with screws. If it is not fastened securely, the instrument may fall when you grasp the handgrip, leading to possible injury.
- Do not short the poles of the battery or charger as there is a risk of injury or fire.
- Do not touch any fluid which may leak from the battery as there is a risk of chemical burn injury or reaction.
- Do not insert or remove the electric plug with wet hands as there is a risk of electric shock.
- Do not use the case to stand on as it is slippery and unstable and may cause you to fall, resulting in possible injury.
- Be sure the tripod itself and the instrument on the tripod are both installed securely as insecure installation may cause the tripod to fall over or the instrument to drop, resulting in possible injury.
- Do not carry the tripod with the metal shoe pointing toward another person as it may injure him/her.



- The instrument contains a rechargeable battery and a battery charger.
- It may be illegal to dispose the battery at the end of its useful life.
- Check with your local solid waste officials for details for recycling.

[Usage precautions]

Surveying instruments are high-precision instruments. In order to assure that the Electronic Total Station W-800 series product which you have purchased will provide long-lasting maximum performance, the precautions in this manual must be followed. Be sure to follow these instructions and use this product properly at all times.

[Solar observation]



Never view the sun directly using the telescope as this may result in loss of sight. Never point the objective lens directly at the sun as this may damage internal components. When using the instrument for solar observation, be sure to attach the specially designed solar filter (MU64) to the objective lens.



Do not stare into laser beam. W-800 series is a Class IIIa (3R) Laser product.

[EDM axis]

The W-800 series EDM is the red visible laser beam and the beam diameter is very small. The beam is emitted from the objective center and the base plate center hole. The EDM axis is designed to coincide with the telescope sight axis (but both axes may deviate slightly because of intense temperature changes and a long time lapse).

[Target constant]

Confirm the Target Constant of the instrument before measurement.

If a different constant is to be used, use the correct constant of the target. The constant is stored in the instrument's memory when turned off.

[Reflectorless and reflector sheet]

Reflectorless measurement precautions:

- The measurement range and accuracy of Reflectorless are based on the condition that laser beam is emitted perpendicular to the white side of the Kodak Gray Card. There is a possibility that the range may vary when the target does not satisfy the conditions above at survey work. The measurement range may be influenced by the shape of the target and its environment.
- There is a possibility that the instrument may not be able to correctly calculate out the distance when receiving reflected laser beam from forth and back directions in case of measuring the target on the road.
- There is a possibility that measured distance may be longer or shorter than the actual one when measuring a target of slope or sphere or rugged shape as the distance is calculated out from synthesized values.
- There is a possibility that the instrument may not be able to correctly calculate out the distance when receiving reflected laser beam from a man or a car that comes and goes in front of the target.
- There is a possibility that the distance may not be correctly measured when measuring a target in the direction where there is a reflecting object (mirror, stainless board and white wall, etc.) or under too strong sun light.
- In a situation high accuracy may not be expected, perform the measurement by reflector sheet or prism.
- The measurement range at TRACK mode is over 5m.
- It may take longer time than usual when measuring the distance exceeding 300m or the distance to an object that is hard to measure.

Reflector sheet measurement precautions:

- There is a possibility that correct distance measurement may not be performed by dispersion or reduction of laser beam when the laser beam comes into the target from diagonal angle.
- When using reflector sheet, set the reflector sheet to have its surface be perpendicular to the aiming line. If it is positioned not to be perpendicular, there is a possibility that correct distance measurement may not be performed by dispersion or reduction of laser beam.

[Battery & charger]

- Do not use any batteries and battery chargers other than those PENTAX assured adequate.
- If water should happen to splash on the instrument or the battery, wipe it off immediately and allow it to dry in a dry location. Do not put the instrument in the case until it is completely dry as this may result in damage to the instrument.
- Turn off the power when removing the battery from the instrument as removing the battery while the power is still on may result in damage to the instrument.
- The battery mark displayed on the instrument is only an estimate of remaining battery power and is not completely accurate. Replace the battery quickly when it is about to run out as the time a battery lasts on one full charge differs depending on conditions of ambient temperature, and the measurement mode of the instrument.
- Confirm the battery level remaining before operating.

[Auto focus]

The Auto focus mechanism is very precise but will not function under every condition. Focusing depends on brightness, contrast, the shape and size of the target. In such a case, press the AF button and focus on the target by operating the Power focus key or the Focus ring.

[LD POINT, laser pointer]

When making a correct direction using the "LD POINT", aim the laser beam at the wall and mark the center and then confirm the discrepancy between the reticle center and the marked point beforehand.

[Interface]

Do not insert or remove SD card, CF card and USB Connector outdoors.

Be careful not to let dust, mud, sand, water, harmful gas or salty steam enter the card slot or USB connector port. Be sure to turn the instrument's power off before inserting or removing the SD card, CF card or USB Connector.

[Touch panel]

Use the Stylus pen when you touch the panel for operation of software.

Do not touch the panel with any things such as fingertips or pen point as this may scratch and damage the screen.

[Data saving]

When using application software, store data in SD card drive, CF card drive or DiskOnChip folder. Data stored in other drives is deleted when the power is turned OFF.

[Storage and operating environment]

- To prevent making short-circuit when removing the battery and charger from the case and storing them, apply electrically resistant tape to the poles of the battery. Storing the battery and charger as is may result in fire or burn injury due to short-circuit.
- Avoid storing the instrument in places subject to extreme high, low or radically fluctuating temperature. (Ambient temperature range during use: -20°C to $+50^{\circ}\text{C}$)
- Distance measurements may take longer when atmospheric conditions are poor such as when heat shimmer is present. When storing the instrument, always put it in its case and avoid storage in dusty location or location subject to vibration or extreme heat or humidity.
- Whenever there is a sharp temperature difference between the instrument's storage and usage environment, allow the instrument to adjust to the environment for an hour or more before using it. Be sure to protect the instrument from the sun if the location is subject to intense direct sunlight.
- During surveys for which the survey precision or atmospheric measurement method has been defined measure the atmospheric temperature and pressure separately and enter those values rather than using the Automatic Atmospheric Correction function.
- The battery should be charged approximately once per month if the instrument is to be stored for an extended period of time. The instrument should also be removed from its case occasionally and aired out.
- In addition to these precautions, be sure to handle the instrument properly at all times following the descriptions given in the various sections of this manual to assure safe and proper measurements.

[Transporting and carrying the instrument]

- Be careful to protect this instrument from shock of impact and excessive vibration which may result in damage during transportation and shipment.
- When transporting the instrument, always put it in the case and wrap shockabsorbing material around it and be sure it is handled as "FRAGILE".

[Checks and repairs]

- Always check the instrument before beginning work and check that the instrument is maintaining the proper level of precision. Pentax bears absolutely no responsibility for damages due to survey results obtained from surveys conducted without an initial instrument check. Never disassemble the instrument, battery or charger even if you do detect an abnormality as there is a risk of fire or electric shock due to short-circuit. If you think the product requires repair, contact the retail outlet where you purchased it or an authorized repair site.
- Never disassemble the instrument, battery or charger even if you do detect an abnormality as there is a there is a risk of fire or electric shock due to short-circuit, If you think the product requires repair, contact the retail outlet where you purchased it or an authorized repair site.

CONTENTS

PRECAUTIONS REGARDING SAFETY	1
SAFETY PRECAUTIONS (MUST BE FOLLOWED)	1
USAGE PRECAUTIONS	3
1. BEFORE USING THE INSTRUMENT	9
1.1 NAMES OF PARTS	9
1.2 UNPACKING AND PACKING	10
1.3 STANDARD EQUIPMENT	10
1.4 ATTACHING AND CHARGING THE BATTERY	11
1.5 INSERTING / REMOVING SD CARD	14
1.6 INSERTING / REMOVING CF CARD	15
1.7 CONECTING USB CABLE	16
1.8 INTERNAL MEMORY	17
1.9 DETACHING / ATTACHING STYLUS PEN	17
2. DISPLAY AND KEYBOARD	18
2.1 DISPLAY AND KEYBOARD	18
2.2 OPERATION KEYS	18
2.3 ALPHANUMERIC INPUT	19
2.4 LD POINT, LASER POINTER	19
3. PREPARATION FOR SURVEYING	20
3.1 CENTERING AND LEVELING OF THE INSTRUMEN	20
3.2 LASER PLUMMET	21
3.3 LEVELING WITH CIRCULAR VIAL	22
3.4 EYEPIECE ADJUSTMENT	23
3.5 TARGET SIGHTING	24
3.6 ATTACHMENT AND DETACHMENT OF TRIBRACH	28
4. CHECKS AND ADJUSTMENTS	29
4.1 ELECTRONIC VIAL	29
4.2 CIRCULAR VIAL	30
4.3 VERTICAL RETICLE	31
4.4 PERPEND CULARITY OF LINE OF SIGHT TO HORIZONTAL AXIS	32
4.5 VERTICAL 0 POINT ERROR	32
4.6 LASER PLUMMET	33
4.7 OFFSET CONSTANT	33
4.8 BEAM AXIS AND LINE OF SIGHT	34
4.9 THE EDM BEAM AXIS	34

5. SPECIFICATIONS	35
6. APPENDIX	37
6.1 ATMOSPHERIC CORRECTION	37
6.2 hpa AND mmHg CONVERSION TABLE	37
6.3 ERROR WHEN NO ATMOSPHERIC CORRECTION IS MADE	38
6.4 ATMOSPHERIC REFRACTION AND EARTH CURVATURE CORRECTION	39
6.5 DISTANCE RANGE	40
7. NOTICE TO THE USER OF THIS PRODUCT	41

1. BEFORE USING THE INSTRUMENT

1.1 Names of parts



Objective lens



A shift fixed screw is attached to Base plate of a shift base type model.

1.2 Unpacking and packing

[Unpacking the Instrument from the case]

- Å Set the case down gently with the lid facing upwards.
- Ç Open the latches while pressing down on the lock (safety mechanism) and open the lid of the case.
- E Remove the instrument from the case.

[Packing the Instrument in the case]

- Å Make sure the telescope is fairly level and lightly tighten the telescope clamp screw.
- Ç Line up the housing marks (round yellow marks on the instrument) and tighten the upper and lower clamp screws.
- E With the housing marks facing upward, set the instrument gently in the case without forcing it.
- N Close the lid to the case and secure the latches.

1.3 Standard equipment

- Instrument
- Carrying case
- BP02 battery
- BC03/AC01 charger
- Plumb bob
- Hexagonal wrench
- Rain cover
- Quick Reference Guide
- CD

1.4 Attaching and charging the battery

[Removing the Battery]

- Å Turn the Battery latch anticlockwise and remove the battery pack.
- Ç Lift up the battery pack and remove it from the instrument.
- Be absolutely sure to turn the power off when removing the battery pack as removing the battery pack while the power is still on may result in damage to the instrument.



[Attaching the battery]

- Å Align the guide grooves on the battery pack with the guide grooves on the instrument and push the top of the battery pack into place.
- Ç Turn the Battery latch clockwise to fix.



- Turn and fix the Battery latch to lock the battery pack while in use

[Charging the battery]

- The battery BP02 is not charged at our factory shipment. It must be charged before use.
- For BP02 charge, use the special BC03 charger.

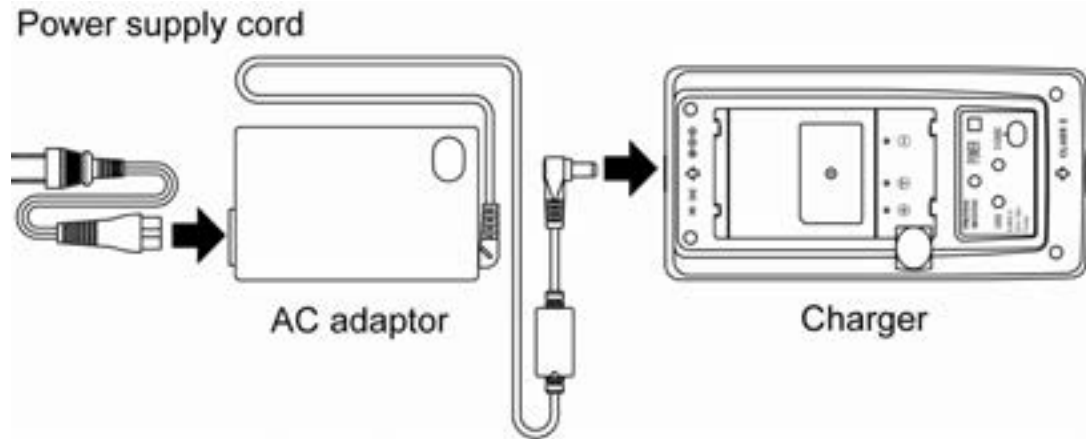

[Connection of code]

- Å Insert the output plug of the power supply code in Jack of the AC adaptor.
- Ç Insert the output plug of the AC adaptor in Jack of the charger.
- E Insert the power supply plug of the power supply code in the outlet of AC power supply.

[Installation of battery]

- Å Draw the battery to the lock lever side and put it on the battery pocket. The battery is firmly installed on the battery pocket.
- Ç Press down the battery and then slide it to the opposite direction of the lock lever.
- E The lock lever goes up, and the battery is fixed.
- N Under such a condition, if "Connection of the code" is done, the charge with the battery is begun.

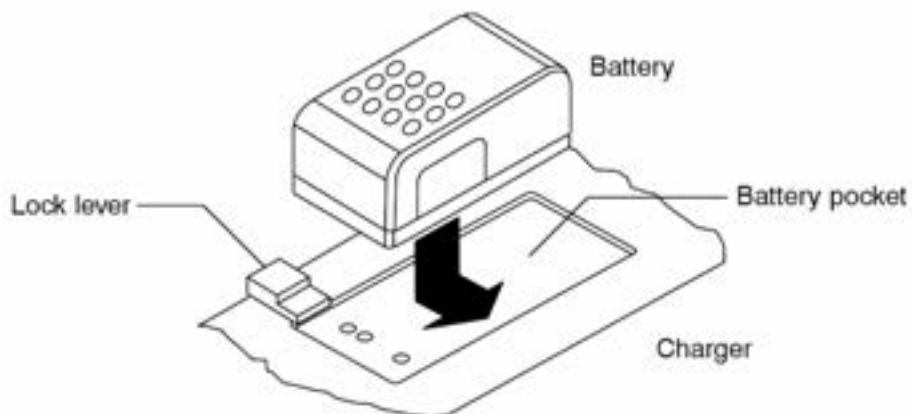

[Detaching the battery]

- Å Press the lock lever and slide the battery to the lock lever direction.
- Ç Detach the battery packing from the battery pocket.

[Display panel]

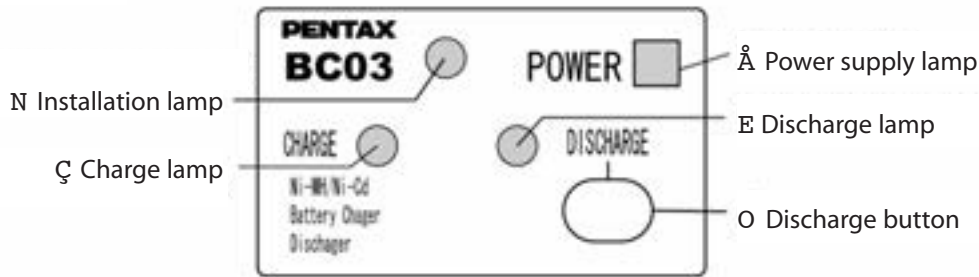

- Å Power supply lamp (red): Turns on when the power supply is turned on.
- Ç Charge lamp (green): Turns on while charging and turns off when the charge is completed.
- E Discharge lamp (yellow): Turns on when you push the discharge button. Turns off when the discharge is completed.
- N Installation lamp (red): Blinks or turns on when the battery packing is attached normally. Blinks when charge or discharge and turns on when charge is completed. (The charge lamp in the lower does not blink and does not turn on)
- O Discharge button: Discharge lamp lights when you push this button, and the discharge of battery begins.

[How to charge]

- Å It begins charging automatically when you set the battery packing in the charger which beams the power supply lamp.
- Ç Leave just as it is until the charge is completed.
- E When the charge is completed, the charge lamp is turned off.
- N Detach the battery packing from the charger when the charge is completed.

[Refreshing the battery]

The use time shortens gradually by the phenomenon of "Effect of the memory" when the NiMH battery leaves capacity and repeats the charge. The voltage recovers after refreshing and the use time returns normally in such a battery. Please refresh one degree every five times of the charge.

[Refreshing]

Set the battery in the charger as well as the case of the charge. Push the electrical discharge button. The electrical discharge lamp lights and the electrical discharge begins.

The electrical discharge lamp is turned off when the electrical discharge ends, the charge lamp lights, and the charge starts automatically. Leave just as it is until the charge is completed. When the charge is completed, the charge lamp is turned off. Detach the battery from the charger.

[Time of refreshing and charge]

Battery BP02 is discharged from the state of a full charge at about 960 minutes and the charge is completed from the electrical discharge at about 130 minutes. However, the electrical discharge time is proportional to the remainder capacity of the battery. Moreover, the time required for refreshing might be different from the above-mentioned time according to a surrounding temperature and the state of the battery.

1.5 Inserting / removing SD card

- Be sure to turn the instrument's power off before inserting or removing the SD card.

Inserting SD card

- 1) Open the Slot cover
- 2) Insert the SD card into the slot. (The side with terminal should face the instrument and the cut-off corner should be up).
- 3) Insert the SD card to the end. Be sure not to press the card too hard.
After the SD card is inserted, close the Slot cover completely.



Removing SD card

- 1) Open the Slot cover
- 2) Lightly press the SD card so the card pops out.
- 3) After the SD card is removed, close the Slot cover completely.

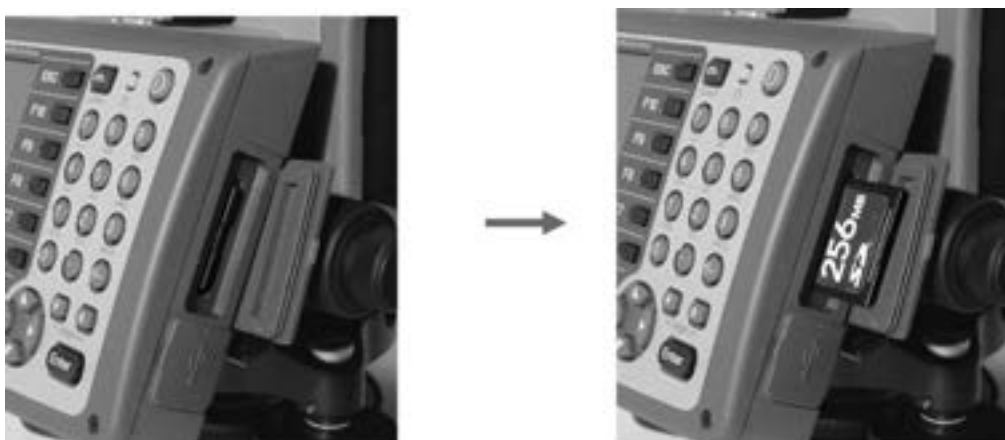

- Do not open/close the Slot cover or insert/remove the SD card outdoors.

1.6 Inserting / removing CF card

- Be sure to turn the instrument's power off before inserting or removing the CF card.

Inserting CF card

- 1) Unlock the CF card slot cover by pressing 'CF OPEN' button, then, open the cover.
- 2) Carefully insert the CF card into the Slot until the Inject button pops out.
(The side with terminal must face the instrument)
- 3) After the CF card is inserted, close the Slot cover completely.

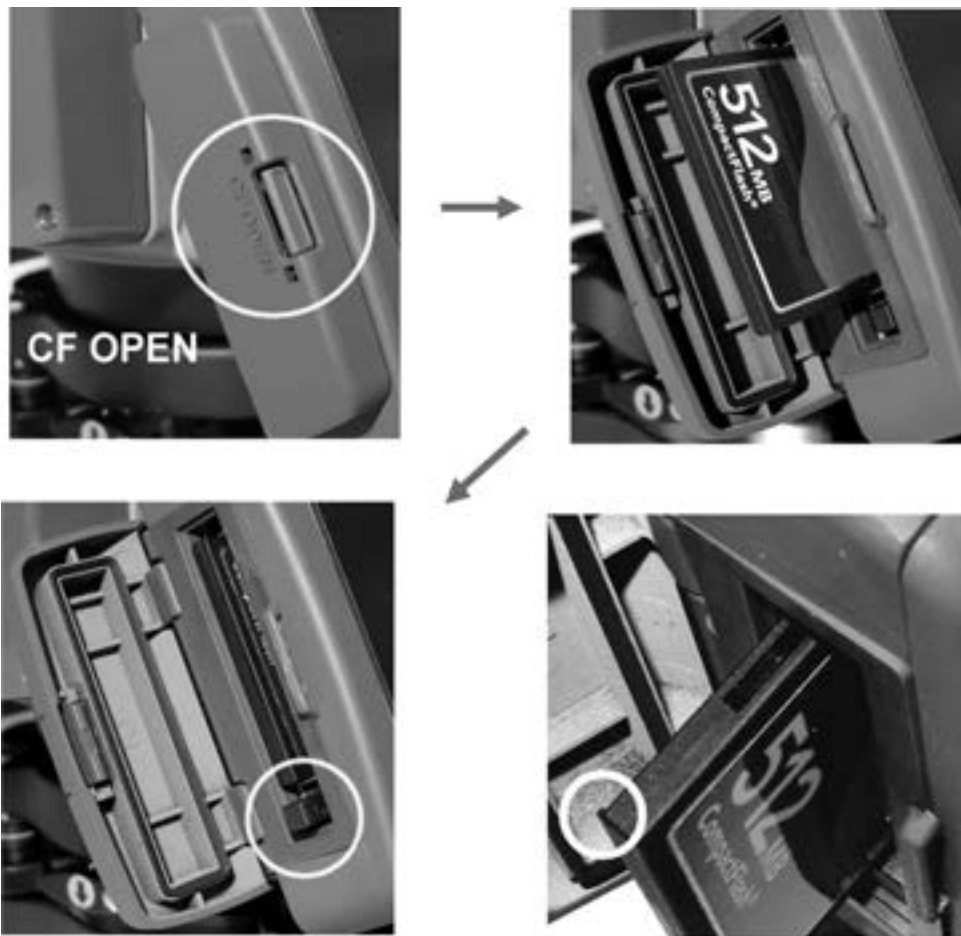

Insert the CF card with its tub facing the instrument.

- Do not open / close the Slot cover or insert / remove the CF card outdoors.

Removing CF card

- 1) Unlock the CF card slot cover by pressing 'CF OPEN' button, then, open the cover.
- 2) Press the Inject button so the CF card pops out.
- 3) After the CF card is removed, close the Slot cover completely.

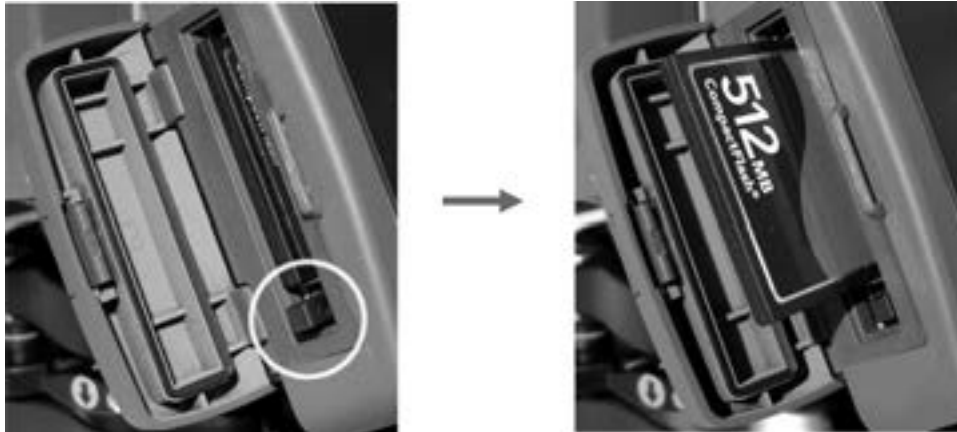

1.7 Connecting USB cable

- Be sure to turn the instrument's power off before connecting or disconnecting the USB Cable.
- 1) Open the USB connector cover
 - 2) Insert the USB connector into the USB port in right direction.
 - 3) After the USB is disconnected, close the USB connector cover completely.



Be sure the direction of USB mini B connector is same as that of the USB port.

- Do not open/close the USB connector cover or connect/disconnect the USB cable outdoors.

1.8 Internal memory

W-800's internal memory stores data in a folder named DiskOnChip in /MyComputer. Be sure not to connect W-800 and a PC with USB cable and transfer the stored files in the DiskOnChip or delete the file using the PC.

1.9 Detaching / attaching Stylus pen

Stylus pen is attached behind the LCD unit.



Touch panel input

Selection of functions can be done by touching the display with Stylus pen. Do not touch the display with any things such as fingertips or pen point. Otherwise it may cause malfunction or damage to the display.













2. DISPLAY AND KEYBOARD

2.1 Display and keyboard



2.2 Operation keys

Key	Description
	Used to turn ON/OFF power supply
	Used to return to previous screen or cancels an operation.
	Used to turn ON/OFF the illumination of the LCD display.
	Used to accept the selected (highlighted) choice or value displayed on the screen.
[LASER]	Used to operate the functions such as Laser plummet, electronic vial and Laser pointer.
[Alphanumeric]	Used to input alphabets and numerical value.
 	Used to display the data 1 page back or 1 page ahead.
 	Used to move the cursor up or down.
 	Used to move the cursor left or right

2.3 Alphanumeric input

The point name is inputted by the Alphanumeric keys as following.

Key	Letter under Key	Letter & Figure order to input
[0]		[@][.][_][-][:][/][0]
[1]	PQRS	[P][Q][R][S][p][q][r][s][1]
[2]	TUV	[T][U][V][t][u][v][2]
[3]	WXYZ	[W][X][Y][Z][w][x][y][z][3]
[4]	GHI	[G][H][I][g][h][i][4]
[5]	JKL	[J][K][L][j][k][l][5]
[6]	MNO	[M][N][O][m][n][o][6]
[7]		[][?][!][_][^-][^][I][&][7]
[8]	ABC	[A][B][C][a][b][c][8]
[9]	DEF	[D][E][F][d][e][f][9]
[.]		[.][,][:][;][#][()[]]
[+/-]		[+][-][*][/][%][=][<][>]

2.4 LD POINT, Laser Pointer

How to activate/terminate the laser beam emission differs depending on application software. For exact method of activating/terminating laser beam emission, refer to the instructions in the manuals of respective software.

- The Laser indicator is turned on and the  mark on the left of the screen blinks while the Laser pointer function is operating.
- The beam of the sun is strong and visual confirmation is difficult in daytime when outdoors.
- The laser beam is designed not to be able to observe through the telescope.
- Please visually align the laser beam to the target and mark the center. Confirm the alignment (horizontal and vertical) before measuring when performing accurate work like stake out when using the Laser pointer function.
- Please do not look at the laser source of beam directly.

3. PREPARATION FOR SURVEYING

3.1 Centering and leveling of the instrument

[Setting up the instrument and the tripod]

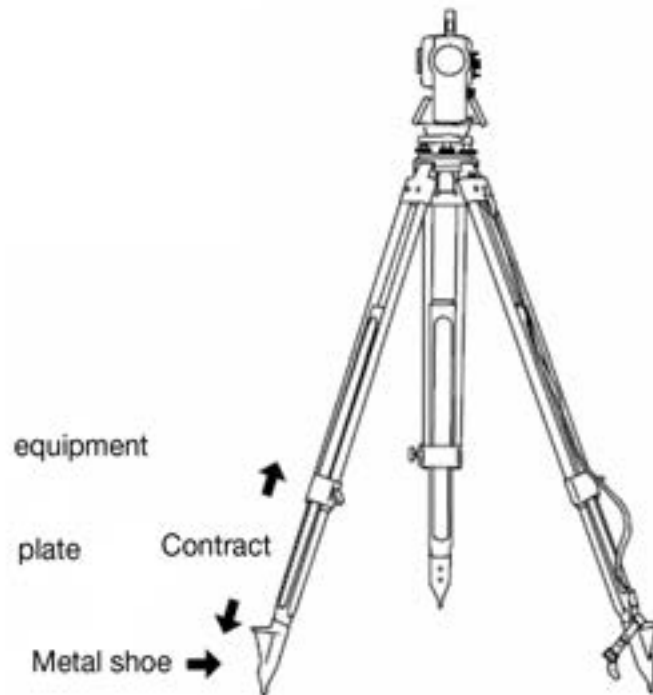

- Å Adjust the tripod legs so that a height suitable for observation is obtained when the instrument is set on the tripod.
- Ç Hang the plumb bob on the hook of the tripod, and coarse center over the station on the ground. At this time, set the tripod and fix the metal shoes firmly into the ground so that the tripod head is as level as possible, and the plumb bob coincides with the station on the ground.
- È If the tripod head is mis-leveled by the action of fixing the metal shoes into the ground, correct the level by extending or retracting each leg of the tripod.
- Ñ Setting up and turn on.

3.2 Laser plummet

- Turn on the laser plummet function.

How to activate/terminate the laser beam emission differs depending on application software. For exact method of activating/terminating laser beam emission, refer to the instructions in the manuals of respective software.

The brightness adjustment step of the laser is 10 steps.

- ⊔ Match the position by the tripod so that the laser mark coincides with the ground mark.

Rotate the instrument by 90°, and confirm the vial of the the electronic vial is at the center at any position. Correct the bubble with the leveling screw when the bubble comes off from the center.

- The laser plummet spot can become difficult to see in bright sunlight which makes it difficult to perform the occasional check. In this case, use your foot or the carrying case to make a shadow over the laser position.



- The laser plummet is adjusted to be within +/- 0.5 mm at the instrument height of 1.5m at factory shipping.
- Please do not look at the laser source of beam directly.

3.3 Leveling with circular vial

Tripod is adjusted according to the following points by extending or contracting the legs so that the bubble of the Circular vial goes to the center of the circle.

- Shorten the leg at the side of the bubble or extend the leg opposite of the bubble to position the bubble in the center of the vial circle.
 - All three legs are extended or contracted until the bubble is in the center.
- During this process, the foot is not placed on the tripod leg point and the position of the tripod points do not change.

Å Rotate instrument horizontally and make two Leveling screws arbitrarily chosen parallel to the display.

Ç Turn on the Electronic vial function. Put the bubble of the Circular vial in the center of the circle when the display shows "TILT OVER".

E Turn two Leveling screws arbitrarily chosen in an opposite direction mutually and put the vial of the horizontal Electronic vial in the center. (Figure A)

N Put the bubble of the lengthwise Electronic vial in the center by operating the Leveling screw of one remainder. (Figure B)

O The procedures are different according to the state of the Automatic inclination correction as following.

U Confirm whether the plummet is on the ground mark. When you confirm it is not on the mark, loosen the center screw and move the instrument over the ground mark correctly and fix the instrument by a center screw. Repeat from Å to U

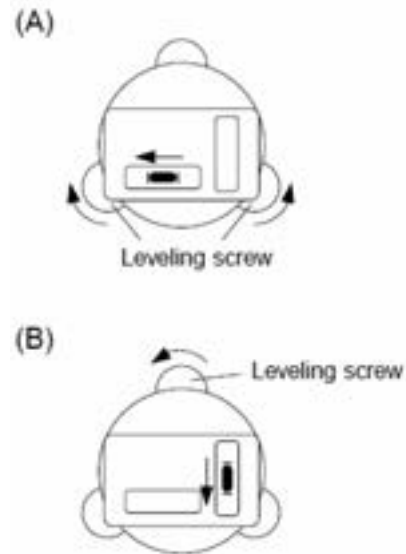

[When using the Automatic inclination correction by 2 axis]

Please read procedure U because the horizontal angle and the perpendicular angle error by a perpendicular axis are automatically corrected.

[When using the Automatic inclination correction by 1 axis]

The instrument is horizontally rotated by 180° after the bubble of the Electronic vial is adjusted on the center at a Left circle position side and confirm that the bubble of the vial is at the center at the right circle position.

[When using without Automatic inclination correction]

Confirm the bubble is at the center even if the instrument is rotated by each 90°.

[Note]

Display or indication of the electronic plummet vary depending on the software to be installed. For more details, please refer to the user manual of the application software.

3.4 Eyepiece adjustment

The eyepiece adjustment is performed before target sighting.

- Å Remove the telescope lens cap.
- Ç Point the telescope at a bright object, and rotate the eyepiece ring full counter-clockwise.
- È Look through the eyepiece, and rotate the eyepiece ring clockwise until the reticle appears as its maximum sharpness.

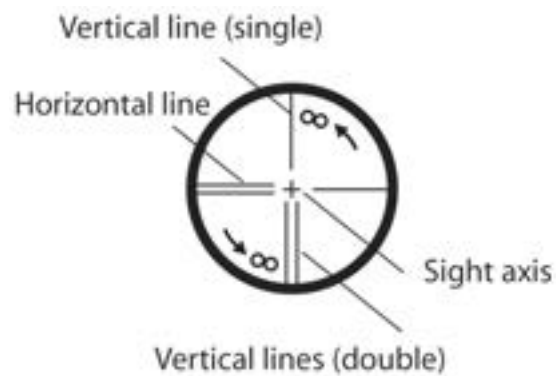

- When looking into the eyepiece, avoid an intense look to prevent parallax and eye fatigue.

3.5 Target sighting

[Auto focus]

The Auto focus mechanism is very precise but will not function under every condition. There is a slight possibility of focusing failure owing to brightness, contrast, the shape and size of the target. In such a case, press the AF button and focus on the target by operating the Power focus key or the Focus ring.

<Target examples which are hard to focus>

No contrast like a white wall

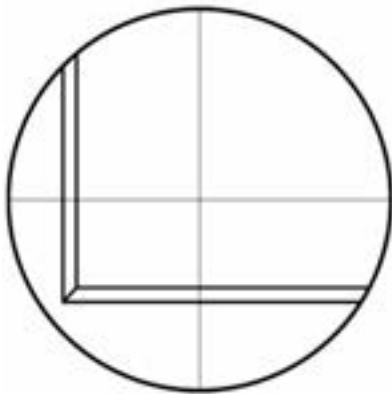

Bright back light



Obstacle in front of a target

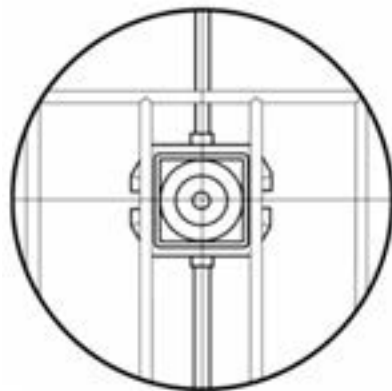

A wall composed of single horizontal lines

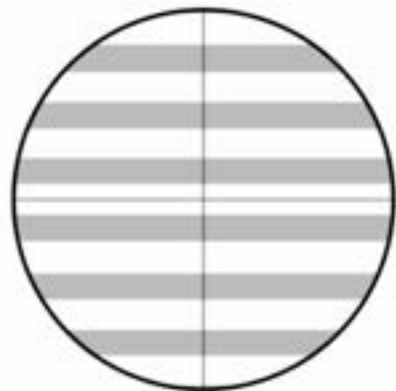

[Target sighting by Auto focus]

The Auto focus of W-800 series has following two modes.

1. Normal mode: Pressing AF button focuses on the target.
2. Continuous mode: Pressing AF buttons for two seconds beeps, and releasing the key enters into the Continuous mode. This mode enables you to perform the Auto focus approx. for one minutes only by sighting through the telescope and following the target.



Normal mode
Continuous mode

Press the AF button.
Press AF buttons for two seconds until it beeps and release the key.

[Auto focus: Target sighting by Normal mode]

- Å Loosen the telescope clamp and horizontal clamp screws.
- Ç Point the telescope at the target using a collimator.
- E Tighten the above two screws.
- N Adjust the eyepiece.
- O Look through the telescope and press the AF button. Move your eye vertically and horizontally to see if the target image moves in relation to reticle.
- U Align the reticle accurately on the target using telescope and horizontal tangent screws.



Collimator

AF button

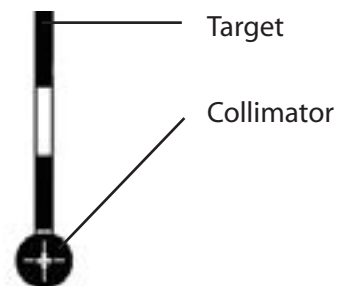

Target

Collimator

Target sighting

- If the target image does not move, there is no parallax. If it moves, eliminate the parallax.
- Even when vertical angle measurement is not performed, it is recommended that the target should be placed at the reticle center.
- Operating the Power focus key rotates the Focus ring, so do not touch it while it is rotating.

[Auto focus :Target sighting by Continuous mode]

- Å Loosen the telescope clamp and horizontal clamp screws.
- Ç Point the telescope at the target using a collimator.
- E Tighten the above two screws.
- N Adjust the eyepiece.
- O Look through the telescope and then press the AF button for two seconds to beep, and release the key to enter into the Continuous mode.
- U Align the reticle accurately on the target using telescope and horizontal tangent screws.
- a Point the telescope to the next target as well.

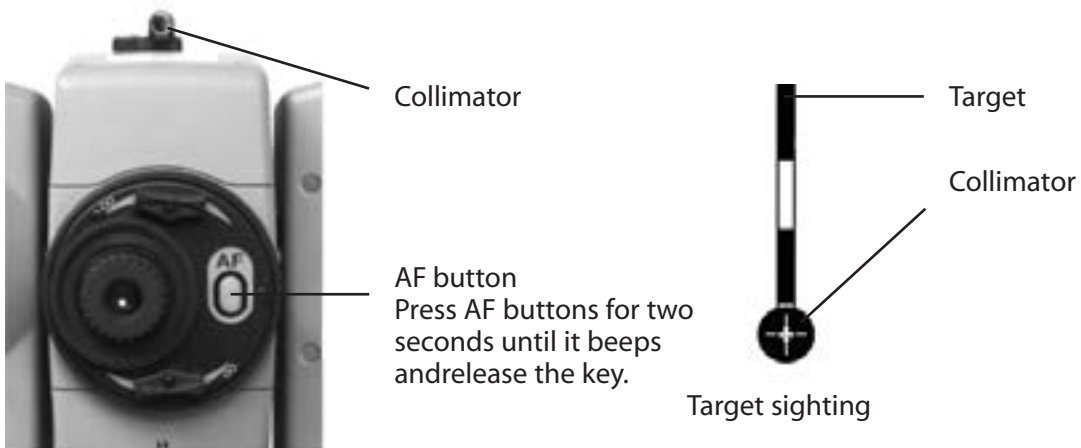

- Keep the target close to the reticle center when following it by the Continuous mode.
- Continuous mode automatically ceases after approx. one minute.
- Pressing the AF button or operating the Power focus key releases the continuous mode.
- Operating the Power focus key rotates the Focus ring, so do not touch it while it is rotating.

[Auto focus :Target sighting by Power focus mode]

- Å Loosen the telescope clamp and horizontal clamp screws.
- Ç Point the telescope at the target using a collimator.
- E Tighten the above two screws.
- N Adjust the eyepiece.
- O Look through the telescope, and then operate the Power focus key and focus on the target.
- U Align the reticle accurately on the target using telescope and horizontal tangent screws.

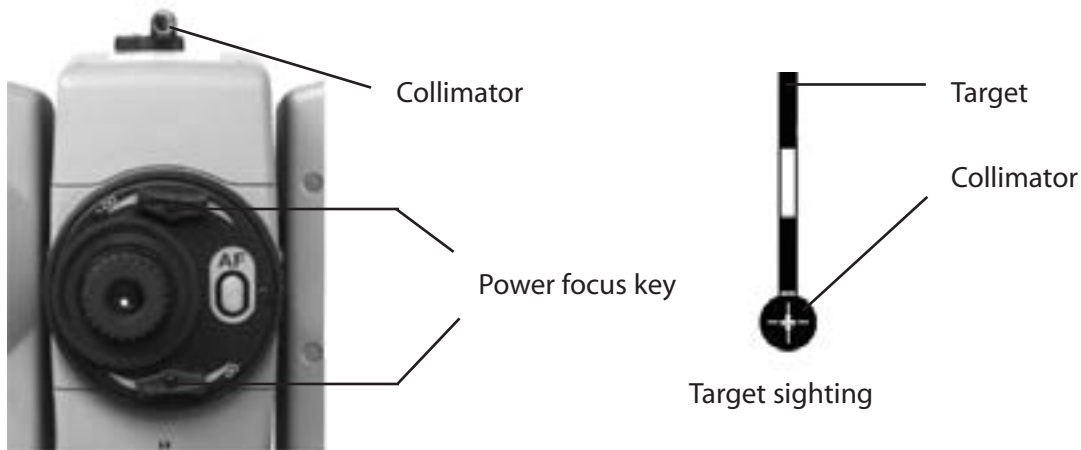

- Tilting the Power focus key “clockwise” makes it possible to focus on closer objects and “counterclockwise” will focus on farther objects.
- Tilting angle of the Power focus key makes it possible to perform following three focusing speeds.
 - Low speed: When tilted to middle position by approx. 5 degrees
 - Middle speed: When tilted fully by approx. 10 degrees
 - High speed: When tilted fully by approx. 10 degrees and passed one second
- Operating the Power focus key rotates the Focus ring, so do not touch it while it is rotating.

[Target sighting by manual focus]

- Å Loosen the telescope clamp and horizontal clamp screws.
- Ç Point the telescope at the target using a collimator.
- E Tighten the above two screws.
- N Adjust the eyepiece.
- O Look through the telescope and then rotate the Focus ring and stop it where the target can be seen clearly and the target image does not move in relation to reticle even if your eye is vertically and horizontally moved.
- U Align the reticle accurately on the target using telescope and horizontal tangent screws.

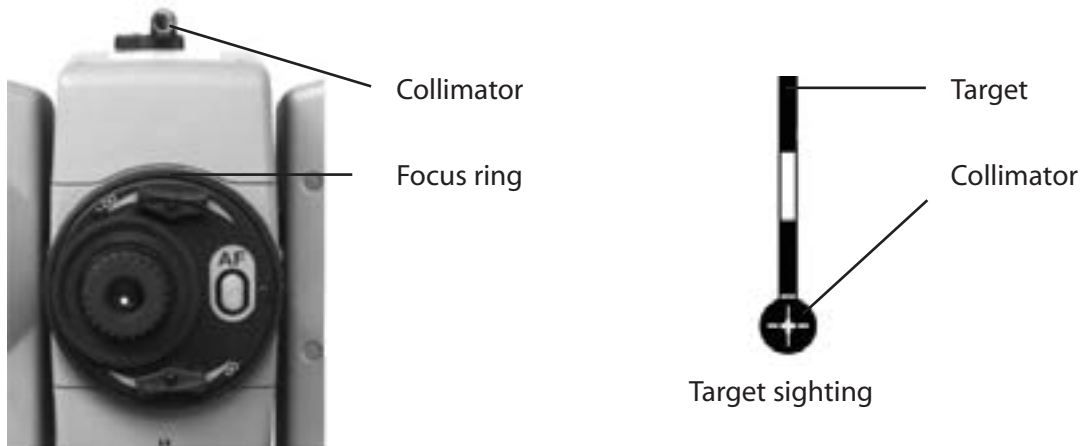

- The Focus ring rotation “clockwise” makes it possible to focus on closer objects and “counter clock wise” will focus on further objects.

3.6 Attachment and detachment of tribrach

The tribrach of W-821NX, W-822NX, W-823NX, and W-825NX are detachable from the instrument if required when replacing the instrument with a target or unit prism for example.

[Detachment]

First loosen the recessed screw with a screwdriver, then rotate the locking knob until the arrow points upward, and lift the instrument up.

[Attachment]

Mount the instrument on the tribrach with the guide marks coinciding, and rotate the locking knob until the arrow points downward. The guide and guide mark must be fitted to attach the instrument. When the tribrach does not need to be attached or detached or instrument is to be transported, tighten the recessed screw with a screwdriver to fix the locking knob.



4. CHECKS AND ADJUSTMENTS

- Checks and Adjustments should be performed before and during measurement.
- The instrument should be checked after long storage and transportation.
- The checks should be performed in the following order.

[Cautions on CHECKS AND ADJUSTMENTS]

- When adjustment is completed, be sure that adjusting screws are completely tightened. When finishing turning adjusting screws, be sure that screws are turned in a direction for tightening.
- Repeat check after adjustment, and check if the instrument has been adjusted properly.
- When adjustment is completed, be sure that adjusting screws are completely tightened. When finishing turning adjusting screws, be sure that screws are turned in a direction for tightening.

4.1 Electronic vial

[Checks]

- Å Align the Electronic vial in parallel with a line joining any two of the leveling screws. Then, adjust the two screws to center the bubble in the Electronic vial.
- Ç Turn two leveling screws in an opposite direction mutually and have the bubble of the side of the electronic vial to the center.
- È Make the bubble of the length of the electronic vial to the center by operating the leveling screw of one remainder.
- Ñ Rotate the instrument by 180° and confirm the position of the bubble of the electronic vial. At this time, it is not necessary to adjust it if the bubble of the electronic vial is in the vicinity of the center.

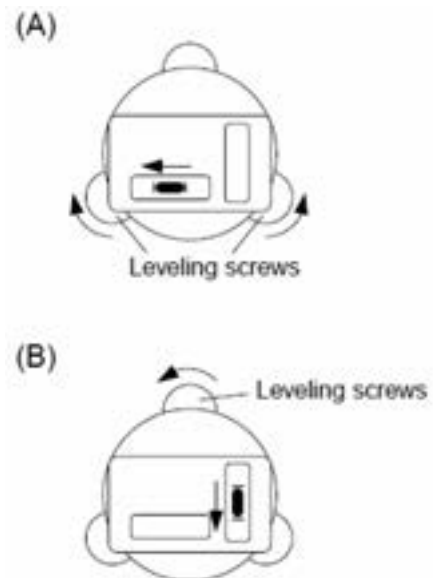

- Please check the electronic vial in a steady environment that has no vibration or rapid temperature change.
- When the electronic vial is checked outdoors and on a tripod, avoid sunlight influence by using a sunshade. Please wait for a while until the instrument and tripod are at the same temperature as the surrounding air.
- When the instrument is seen at the position of "Left circle" movement and the inclination of the instrument become the same on the screen in the electronic vial. Please note that the movement of the bubble becomes opposite direction if it is seen at the position of "Right circle".

[Adjustments]

It is necessary to adjust as following when the bubble is not in the vicinity of the center in the confirmation of Ñ.

4.2 Circular Vial

[Checks]

- Ⓐ Adjust by the electronic vial beforehand.
- Ç Confirm the position of the bubble of the Circular vial.
At this time, it is not necessary to adjust if the bubble is at the center of the circle.

[Adjustments]

When the bubble of the Circular vial comes off from the center according to check procedure Ç, it is necessary to adjust. Turn the bubble adjustment screw with a hex wrench (L type wrench) and put the bubble in the center of the circle.

[Only the detaching type model]

Turn the bubble adjustment screws with the reticle adjustment pin and put the bubble in the center of the circle.

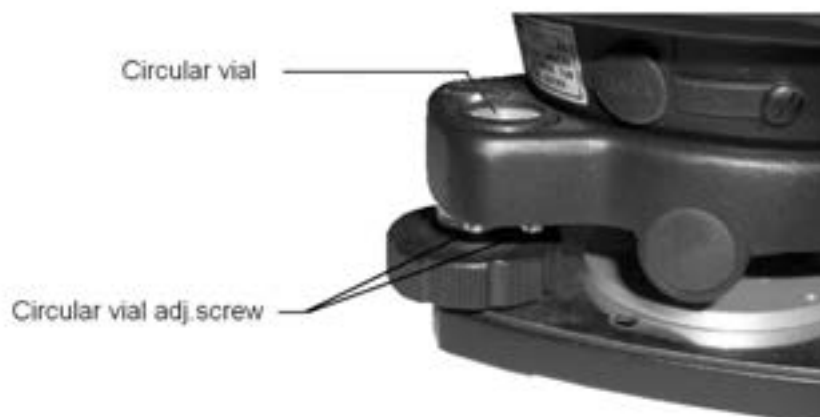
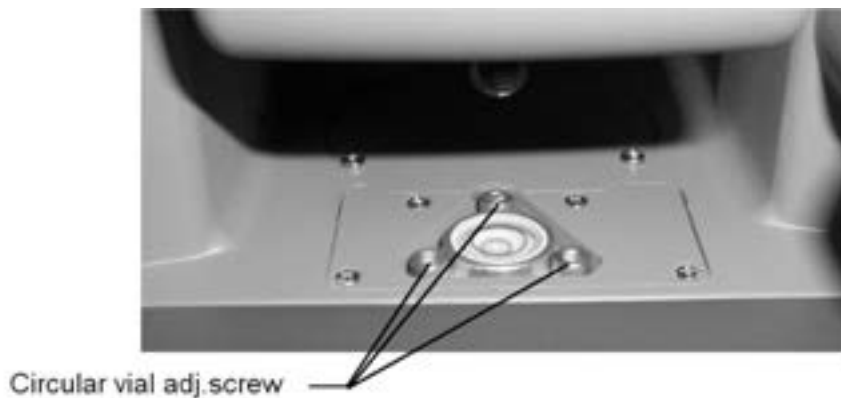

- Tighten the screws equally after the above adjustment.

4.3 Vertical reticle

[Checks]

- Å Set the instrument up on the tripod and carefully level it.
- Ç Sight the target Point A with telescope.
- È Using the telescope fine adjustment screws, move Point A to the edge of the field of view by screw (point A').
- Ñ No adjustment is necessary if Point A moves along the vertical line of the reticle.

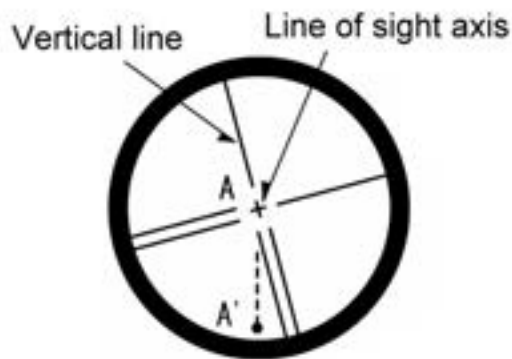

[Adjustments]

- Å If Point A is off from the vertical line of the reticle, first remove the eyepiece cover.
 - Ç Using the adjusting pin, loosen the four reticle adjustment screws slightly loosening each screw by the same amount, and then rotate the reticle line around the sight axis and align the vertical line of the sight axis with Point A'.
 - È Tighten the reticle adjustment screws again by the same amount, and repeat the check to make sure the adjustment is correct.
- * Since the W-821NX, W-822NX and W-823NX have triple axis compensation, it is necessary to make other settings besides the adjustments mentioned above. For details, contact the dealers from whom the instrument was purchased.

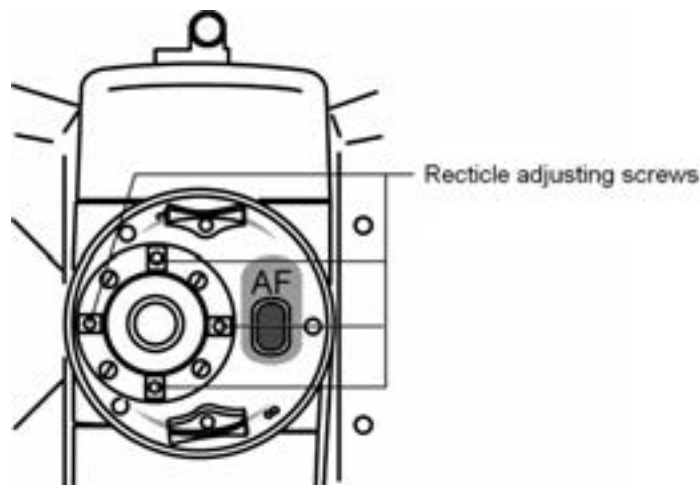

4.4 Perpendicularity of Line of sight to horizontal axis

[Checks]

- Ⓐ Position a target Point A at a distance 30m - 50m away from the instrument, and sight it with the telescope.
- Ⓒ Loosen the telescope lock screw and turn the telescope until a point is sighted at a distance roughly equal to that of Point A. This is Point B.
- Ⓔ With the telescope still reversed loosen the horizontal lock screw and rotate the instrument around the vertical axis, and sight Point A again.
- Ⓖ Loosen the telescope lock screw and turn the telescope until a point is sighted at a distance equal to that of Point B. This is Point C.
- Ⓞ No adjustment is necessary if Point B and C are aligned.

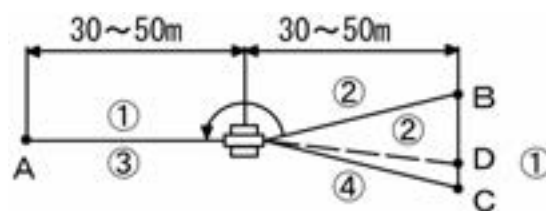

[Adjustments]

- Ⓐ If Points B and C are not aligned, mark Point D at 1/4 the length of the BC, from Point C in the direction of Point B.
- Ⓒ Using the adjustment pin, rotate the reticle adjustment screws horizontally opposite each other (see preceding page), and move the reticle to sight Point D.
- Ⓔ Repeat the check and make sure the adjustment is correct.
- * Since the W-822NX and W-823NX have triple axis compensation, it is necessary to make other settings besides the adjustments mentioned above.
For details, contact the dealers from whom the instrument was purchased.

4.5 Vertical 0 point error

Be sure to follow check procedures mentioned below after making adjustments on reticle and perpendicularity of line of sight to horizontal axis.

[Checks]

- Ⓐ Set up the instrument and turn the power on.
- Ⓒ Sight the telescope at any reference target A at Normal state. Read the vertical angle (\square).
- Ⓔ Turn the telescope and rotate the alidade. Sight the same target A again at Back state and read the vertical angle R.
- Ⓖ If $\square + R = 360^\circ$, no further adjustment is necessary.

[Adjustments]

If the deviation $d (\square + R - 360^\circ)$ is wide, contact your local dealer.

4.6 Laser plummet

[Checks]

- Å Set the instrument on the tripod, and place a piece of white paper with a cross drawn on it right under the instrument.
- Ç Press the [LASER] key, and move the paper so that the intersecting point of the cross comes to the center of the Laser mark.
- E Rotate the instrument around the vertical axis, and observe the center mark position against the intersecting point of the cross at each 90° rotation.
- N If the Laser mark always coincides with the intersecting point, no adjustment is necessary.



[Adjustments]

When a center part where a cross intersection and the laser mark look the brightest shifts by 0.5 mm or more (at the instrument height 1.5m), it is necessary to adjust it. A repair engineer does this adjustment. Please contact the PENTAX dealer.

4.7 Offset constant

The offset constant rarely changes. It is recommended, however, that check be done once or twice a year. The check of the offset constant can be done on a certified base line. It can also be obtained in a simple way as described below.

[Checks]

1. Locate points A, B and C at about 50m intervals on even ground.
2. Set up the instrument at point A, and measure the distances between AB and AC.
3. Set up the instrument at point B, and measure the distance BC.
4. Obtain the offset constant (K):
 $K = AC - (AB+BC)$

[Adjustments]

- Contact your local dealer for adjustment of the off-set constant when the K is not nearly 0.

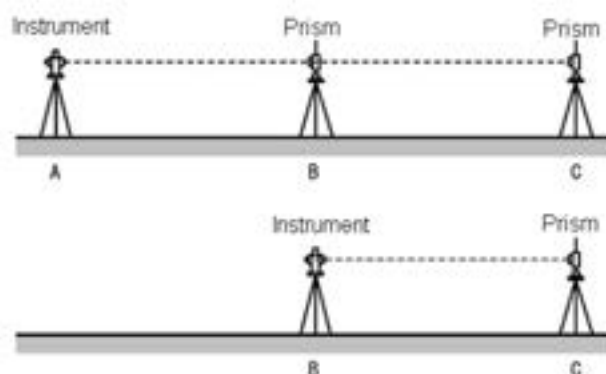

4.8 Beam axis and line of sight

Be sure to check that the beam axis and line of sight are aligned when the adjustments on reticle and perpendicularity of line of sight to horizontal axis are made.

[Checks]

- Å Set the prism at a distance greater than 50 m.
- Ç Accurately sight the center of the prism through the telescope.
- E Turn the power on and press [MEAS] to measure.
- N No adjustment is necessary if beam receiving buzzer sounds immediately and measurement value is displayed in a few seconds.

[Adjustments]

- If instrument function is not as described in N, contact your local dealer.
- This check should be done under good weather conditions.

4.9 The EDM beam axis

The distance measurement (EDM) beam axis is adjusted to be aligned to the sighting axis of the telescope, but it can be changed a little in case of rapid temperature change, shock or aging. Check your instrument by following procedures.

[Checks]

- Å Install the instrument on the tripod and level it at the distance of approx. 50 m from the wall.
- Ç Displace the target plate attached to the end of this manual. Place the target plate adjusting its center to the center of telescope cross line and to be about horizontal to the instrument.
- E Turn the power on and set target type to 'Reflector sheet'.
- N When starting measurement, the laser spot is will appears on the target. The adjustment is not necessary if the center of the laser spot stays within 10 mm from the center of the target.

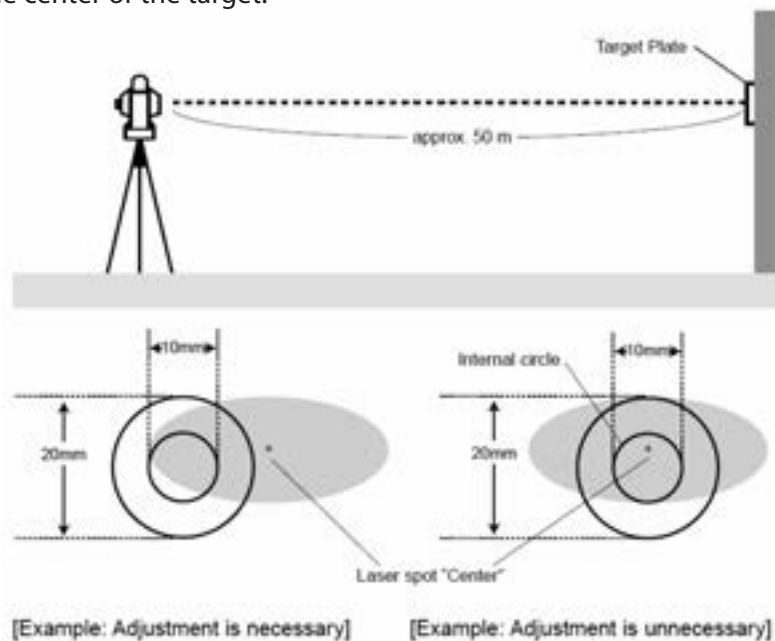

[Adjustments]

At the procedure 4. above, if the "Center" of laser spot is not within the internal circle (10mm) of the target plate, the adjustment is necessary. Please contact your PENTAX dealer.

5. SPECIFICATIONS

Model		W-821NX	W-822NX	W-823NX	W-825NX	W-835NX
Telescope	Magnification	30x				
	Effective aperture	45mm (EDM 45mm)				
	Resolving power	3.0"				
	Field of view	2.6% (1° 30')				
	Minimum focus	1.0 m				
	Focus	Auto focus / Power focus / Manual				
Distance measurement	Laser class	Visible Laser: Class IIIa (3R) (Reflectorless)/ Class II (2) (Prism. sheet)				
Measurement range (Good condition) ③						
	Reflectorless ①	1.5 ~ 550m				
	Reflectorsheet ②	1.5 ~ 600m (800m)				
	Mini Prizm	1.5 ~ 2500m (3000m)				
	1P	1.5 ~ 7000m (9000m)				
	3P	1.5 ~ 9000m (9999m)				
Accuracy ④	Prism / Reflector Sheet	1.5m ~ 10m: ± (3+2ppm x D)mm 10m ~ : ± (2+2ppm x D)mm				
	Reflectorless	1.5m ~ 300m: ± (5+2ppm x D)mm 300m ~ : ± (7+10ppm x D)mm				
At Auto-ATM. Correction						
	Prism / Reflector Sheet	1.5m ~ 10m: ± (3+10ppm x D)mm 10m ~ : ± (2+10ppm x D)mm				
	Reflectorless	1.5m ~ 300m: ± (5+10ppm x D)mm 300m ~ : ± (7+18ppm x D)mm				
	Minimum count	0.1mm (Fine mode), 1mm (Normal mode), 10mm (Track mode)				
Measurement time ⑤						
	Repeat meas. Normal (1mm):	Prism, Ref.sheet 2.0sec. Ref. less 2.0sec.				
	Quick (1mm):	Prism, Ref.sheet 1.2sec. ⑥				
	Track (10mm):	Prism, Ref.sheet 0.4sec. Ref. less 0.4sec.				
	Initial meas. Normal (1mm):	Prism, Ref.sheet 2.5sec. Ref. less 2.4sec.				
	Quick (1mm):	Prism, Ref.sheet 1.7sec. ⑥				
	Track (10mm):	Prism, Ref.sheet 2.5sec. Ref. less 2.5sec.				
Angle measurement						
	Measuring method	Absolute Rotary encoder				
	Detection method	Vertical / Horizontal angle: 2 sides				
	Minimum count	1" / 5" selectable				
	Accuracy (ISO 17123-3)	1"	2"	3"	5"	
Compensator			3 axis ⑦			2 axis
Tangent screw			2 speed			1 speed
Sensitivity of vials						
	Plate level (electronic)	30"/1div.				
	Circular level	8'/2mm				
Plummet			Visible Laser, ±0,5mm (instrument height 1.5m)			
Base			Detachable		Shifting	
	Dust and Water Protection	IP54 (instrument only)				
Ambient temperature			-20°C ~ 50°C / -4°F ~ 122°F (Working range)			
Tripod thread			5/8" x 11		35mm P2	
Dimensions / Weight						
	Dimension	197(W) x 347 (H) x 217 (L)mm				
	Weight (incl. Battery)	6.3 kg			6.2 kg	
	Carrying case	380(W) x 292 (H) x 475 (L)mm / 3.2 kg				
Battery pack BP02						
	Power source	Ni-MH 4300mAh (Rechargeable), DC6.0V				
	Operation time	Approx. 7 hours (single measurement every 30 seconds)				
	Weight	380g				
Battery charger BC03 and AC Adapter AC01						
	Input voltage (AC01)	AC 100 ~ 240V				
	Output voltage (BC03)	DC7.5V				
	Weight	280g				

Model	W-821NX	W-822NX	W-823NX	W-825NX	W-835NX	
Data Processor	CPU, Clock frequency	Intel® XScale, 400MHz				
	OS	Microsoft® Windows® CE.NET 4.2				
	Application software	Selectable				
	Internal memory	SDRAM = 64MB FLASH = 128MB (built-in)				
	Memory card	2GB (Max) ⑧				
	I/F	RS-232C , CF Type II , SD CARD , USB				
Display / Keyboard	Display type	3.7 inch, Color LCD, 640x480 pixels ⑨ with back light and touch panel function				
	Quantity	2		1 (2nd optional)		
	Keys	33 each (12 numeric / 11 function / 10 special)				
	Display back light	Intensity settings: 10 steps				
Laser Pointer	Yes					
Date clock	Yes					

[Note]

- ① The measurement range and accuracy of reflectorless, and time required to measure may vary by the shape, size of surface area and reflection rate of the target and its environment. The measurement range of reflectorless is determined by the white side of the Kodak Gray Card.
- ② Reflector sheet: PENTAX genuine Reflector sheet
- ③ The measurement range may vary by conditions of the environment.
Normal conditions: 20km visibility with slight shimmer
Good conditions: 40km visibility, overcast, no heat, no shimmer and moderate wind.
- ④ When automatic atmospheric correction is on, the EDM error is 10ppm in prism and reflector sheet mode.
- ⑤ EDM measuring time is determined in good conditions. It may takes longer than usual to measure the distance exceeding 4000m in prism mode and 300m in reflectorless mode.
- ⑥ Quick mode, which functions with prism and reflector sheet, is effective only under normal mode(1mm) and up to 500m.
- ⑦ In addition to dual-axis correction in the (X) and (Y) direction, mechanical error in the instrument is corrected.
- ⑧ Memory card is not supplied with the instrument.
- ⑨ Depending on application software.

Remarks: The brand names mentioned in the specifications are a trademark or a registered trademark of each company.

6. APPENDIX

6.1 Atmospheric correction

The speed at which light travels through the air varies depending on the temperature and atmospheric pressure. The W-800 series is designed to measure distances at the speed of light in order to measure accurately, atmospheric correction needs to be used. The instrument is designed to correct for weather conditions automatically if the temperature and pressure are input. Correction is then carried out based on the following formula.

Calculation formula

$$K = \left(276.26713 - \frac{78.565271 \cdot P}{273.14941 + t} \right) \times 10^{-6}$$

K: Atmospheric Correction Constant

P: Atmospheric pressure (hPa)

t: Temperature(°C)

Distance after Atmospheric Correction D = Ds (1+K)

Ds: Measured distance when no Atmospheric Correction is used.

6.2 hPa and mmHg conversion table

[Converting from hPa to mmHg]

hPa	0	10	20	30	40	50	60	70	80	90
	mmHg	mmHg	mmHg	mmHg	mmHg	mmHg	mmHg	mmHg	mmHg	mmHg
500	375	383	390	398	405	413	420	428	435	443
600	450	458	465	473	480	488	495	503	510	518
700	525	533	540	548	555	563	570	578	585	593
800	600	608	615	623	630	638	645	653	660	668
900	675	683	690	698	705	713	720	728	735	743
1000	750	758	765	773	780	788	795	803	810	818
1100	825	833	840	848	855	863	870	878	885	893
1200	900	908	915	923	930	938	945	953	960	968

[Converting from mmHg to hPa]

mmHg	0	10	20	30	40	50	60	70	80	90
	hPa	hPa	hPa	hPa	hPa	hPa	hPa	hPa	hPa	hPa
400	533	547	560	573	587	600	613	627	640	653
500	667	680	693	707	720	733	747	760	773	787
600	800	813	827	840	853	867	880	893	907	920
700	933	947	960	973	987	1000	1013	1027	1040	1053
800	1067	1080	1093	1107	1120	1133	1147	1160	1173	1187
900	1200	1213	1227	1240	1253	1267	1280	1293	1307	1320

6.3 Error when no atmospheric correction is made

When measurement is carried out with no Atmospheric Correction (with the settings fixed at a temperature of 15°C and an atmospheric pressure of 1013 hPa or 760 mmHg), the Error per 100 meters in temperature and pressure will be shown in the tables below.

- When the actual pressure is 1013 hPa (760 mmHg) and the temperature is 25°C, conducting the measurement with the temperature left at 15°C will result in the measurement being short by 0.9 mm per 100 meters.

[Error table: When hPa (15°C, 1013hPa as standard)]

		Unit:mm							
c° \ hPa	1200	1100	1013	900	800	700	600	500	
45	2.0	-0.5	-2.6	-5.5	-8.0	-10.5	-13.0	-15.5	
35	3.0	0.4	-1.8	-4.7	-7.3	-9.9	-12.5	-15.1	
25	4.0	1.4	-0.9	-4.0	-6.6	-9.3	-12.0	-14.6	
15	5.2	2.4	-0.0	-3.1	-5.9	-8.6	-11.4	-14.2	
5	6.3	3.5	1.0	-2.2	-5.1	-8.0	-10.8	-13.7	
-5	7.6	4.7	2.1	-1.3	-4.2	-7.2	-10.2	-13.1	
-15	9.0	5.9	3.2	-0.2	-3.3	-6.4	-9.5	-12.6	

[Error table: With mmHg (15°C, 760mmHg as standard)]

		Unit:mm						
c° \ mmHg	900	800	760	700	600	500	400	
45	2.0	-1.3	-2.6	-4.6	-8.0	-11.3	-14.6	
35	3.0	-0.4	-1.8	-3.9	-7.3	-10.8	-14.2	
25	4.0	0.5	-0.9	-3.1	-6.6	-10.2	-13.7	
15	5.2	1.5	0.0	-2.2	-5.9	-9.6	-13.3	
5	6.3	2.5	1.0	-1.3	-5.1	-8.9	-12.7	
-5	7.6	3.7	2.1	-0.3	-4.2	-8.2	-12.2	
-15	9.0	4.9	3.2	0.8	-3.3	-7.4	-11.5	

6.4 Atmospheric refraction and earth curvature correction

- Atmospheric refraction and earth curvature correction refers to correcting both the bending of the light beam caused by atmospheric refraction and the effect on the height differential and horizontal distance caused by the earth curvature.
- Correction called "atmospheric refraction and earth curvature correction" is initiated to correct error when the slope distance and vertical angle are caused to determine the horizontal distance and the height differential, with this instrument, the following formula is used to correct these factors.
- Calculation formula when atmospheric refraction and earth curvature correction parameter is set to "ON":

Corrected horizontal distance (H)

$$H = S \left(\cos\alpha + \sin\alpha \cdot \frac{K-2}{2R_e} \cdot S \cdot \cos\alpha \right)$$

Corrected vertical distance (V)

$$V = S \left(\sin\alpha + \cos\alpha \cdot \frac{1-K}{2R_e} \cdot S \cdot \cos\alpha \right)$$

- Calculation formula when atmospheric refraction and earth curvature correction parameter is set to "OFF":

Horizontal distance	$H' = S \cdot \cos\alpha$
Vertical distance	$V' = S \cdot \sin\alpha$

- S: Slope distance
- α : Vertical angle from horizontal
- K: Atmospheric refraction coefficient (0.14 or 0.2)
- Re: Diameter of earth 6378137m

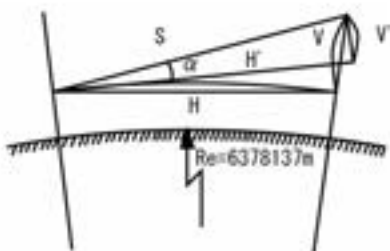

6.5 Distance range

Generally speaking, the maximum range which can be measured varies considerably depending on the atmospheric conditions. For this reason, the Specifications illustrate the values for both Good and Normal weather conditions. It is extremely difficult to judge when weather conditions are "Good" and when they are "Normal". With this instrument, the conditions noted below are used to differentiate between the two situations, (Good weather conditions for surveying are different from Normal weather conditions, and in surveying situations, cloudy skies are considered more favorable than sunny skies.)

Weather conditions for measurement ranges are based on the following standard values:

Normal: Visibility of approximately 20 km, with slight shimmer and moderate wind.

Good: Visibility of approximately 40 km, overcast, with no shimmer and moderate wind.

7. NOTICE TO THE USER OF THIS PRODUCT

To assure compliance with the Safety standard 21 CFR, Chapter 1. Subchapter J. The U.S. bureau of Radiological Health requires the following information to be provided to user:



It can be dangerous to look into the beam with optical equipment such as binoculars and telescopes.

1. Specifications of Laser Radiation

- A) The EDM module of the W-800 series produces a visible light beam, which is emitted from the telescope objective lens and the center hole of the instrument base plate. The W-800 series is designed and built to have a laser diode radiating at 620-690 nm.
- B) Radiant power
The W-800 series is designed and built to radiate a maximum average radiant power of 4.75mW from the telescope, and 0.95mW from the center hole of the base plate. The user may be subject to this radiation as a beam while operation until such time that the instrument is turned off.

2. The following labels are affixed to and must remain attached to this laser product.

- A) The following Certification label is located near the Plate level.:
"This laser product is complied with the provisions of 21 CFR 1040. 10 and 1040.11. For a Class IIIa (3R) laser product."
- B) Caution label is located near the exit aperture:
"AVOID EXPOSURE Laser radiation is emitted from this aperture."
- C) Warning logotype is located on the surface of the telescope:
"DANGER LASER RADIATION AVOID DIRECT EYE EXPOSURE"
- D) Warning label is Located near the exit aperture.

3. Caution to maintain the safety in compliance with the standard

- A) To maintain the safety standard, refrain from any operation, maintenance, or adjustment other than described in this instruction manual.
- B) Operation, maintenance or adjustment other than those specified in this instruction manual may result in hazardous radiation exposure.
- C) Maintenance and repair not covered in this manual must be done by an authorized Pentax dealer.
- D) How to activate/terminate the laser beam emission differs depending on application software. For exact method of activating/terminating the following types of laser beam emission, refer to the instructions in the manuals of respective software.
 - 1) Laser beam emission by the Distance measurement
 - 2) Laser beam emission by the Laser pointer
 - 3) Laser beam emission by the Laser plummet

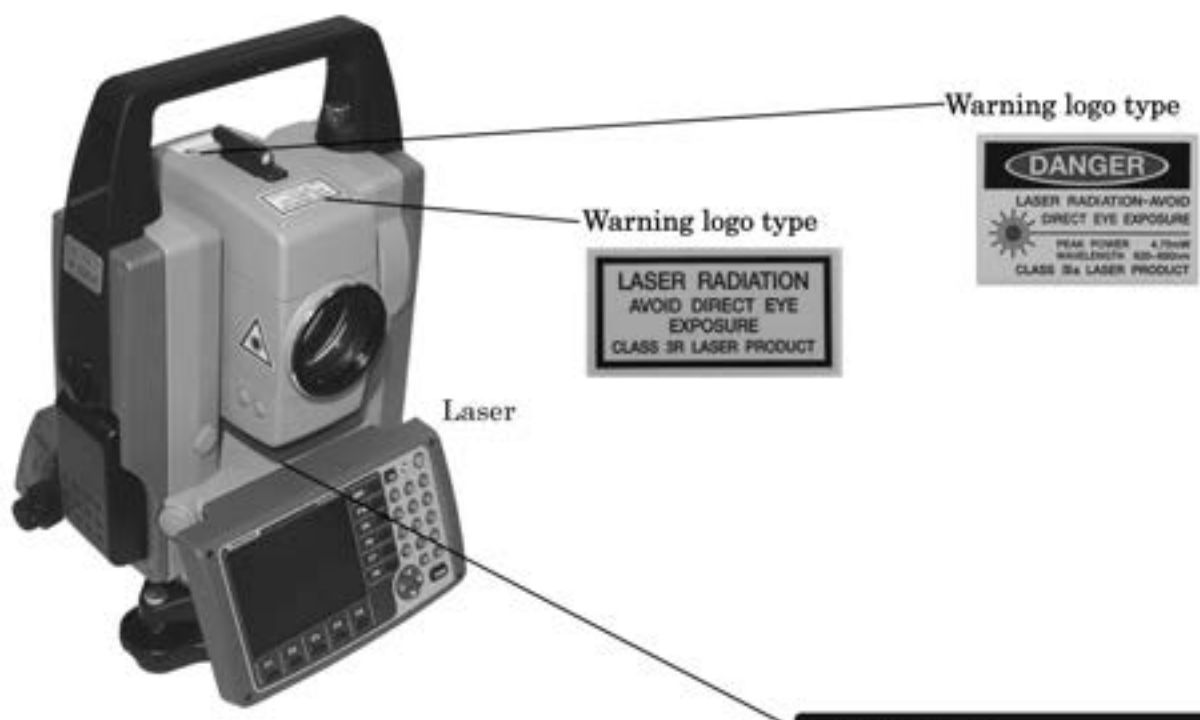
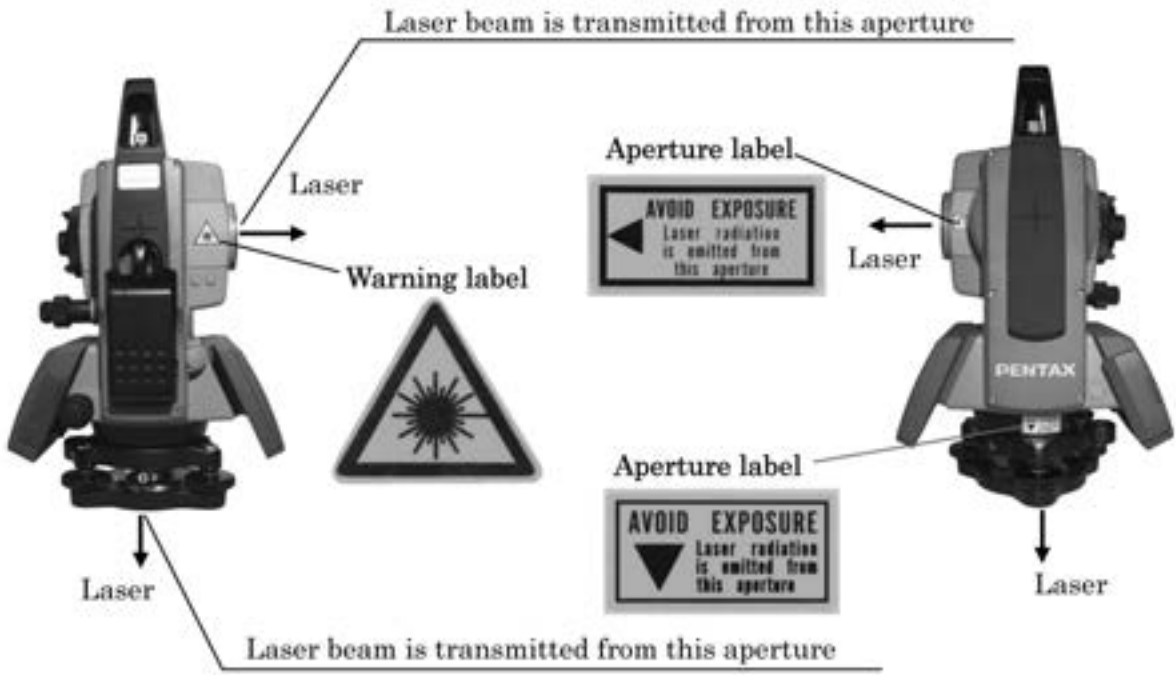

TI Asahi Co., Ltd.
 390, Kakuyama, OgawaMachi, Hiki-Gun, Saitama, 355-0316, Japan
 This laser product is complied with the provisions of 21 CFR 1040.10 and 1040.11. For a class IIIa laser product.
 ASSEMBLED by TI PENTAX Shanghai Co., Ltd.

LED is turned on at the time of emission

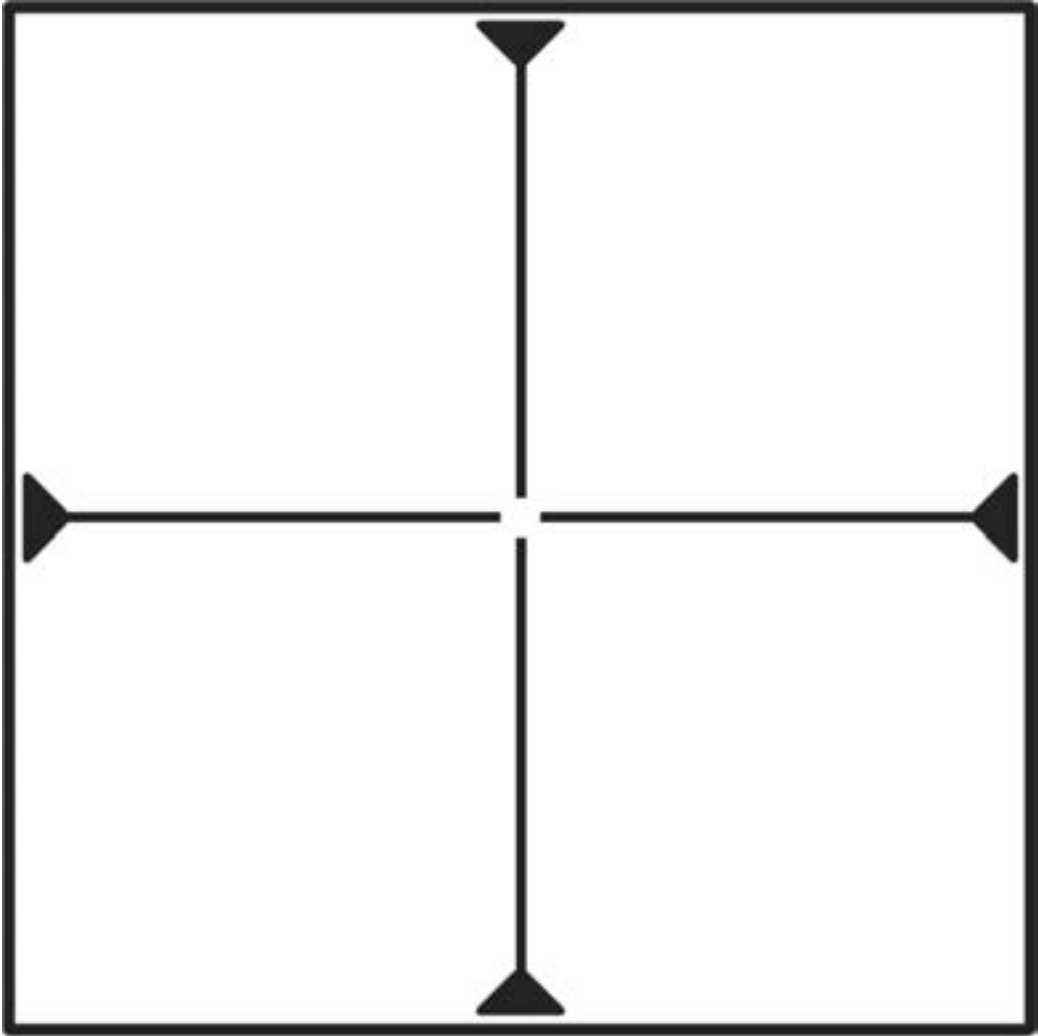

TI Asahi Co., Ltd.

International Sales Department
4-3-4 Ueno Iwatsuki-Ku, Saitama-Shi
Saitama, 339-0073 Japan
Tel.: +81-48-793-0118
Fax. +81-48-793-0128
E-mail: International@tiasahi.com
www.pentaxsurveying.com/en/

Printed in Belgium



JSIMA
Japan Surveying Instruments Manufacturers' Association
*Member symbol of the Japan Surveying
Instruments Manufacturers' Association
representing the high quality
surveying products.*

PENTAX

Copyright © 2013 TI Asahi Co., Ltd. All rights reserved
The duplication, reuse or sale of any information provided on this manual including but not
limited to images, is strictly prohibited without expressed permission from the copyright owners.

01.2013 W800-Basic01A

TOTAL STATION

W-800^{SERIES}

QUICK REFERENCE GUIDE

W-821NX
W-822NX
W-823NX
W-825NX
W-835NX



TI Asahi Co., Ltd.

International Sales Department
4-3-4 Ueno Iwatsuki-Ku, Saitama-Shi
Saitama, 339-0073 Japan
Tel.: +81-48-793-0118
Fax. +81-48-793-0128
E-mail: International@tiasahi.com
www.pentaxsurveying.com/en/

PENTAX

Before using this product, be sure that you have thoroughly read and understood this instruction manual to ensure proper operation. After reading this manual, be sure to keep in a convenient place for easy reference.

This Quick Reference Guide explains about the essential ways of handling the hardware of the W-800 series and cautions required in handling it.

For further detailed information on the W-800 series, please refer to Basic Instruction Manual contained in the CD supplied with the instrument.

For the operations of application software, please refer to their respective manuals.

Copyright © 2012 TI Asahi Co., Ltd. All rights reserved

The duplication, reuse or sale of any information provided on this manual including but not limited to images, is strictly prohibited without expressed permission from the copyright owners.

PRECAUTIONS REGARDING SAFETY

Safety Precautions (Must be followed)

The following items are intended to prevent possible injury to the user or other people and/or damage to the instrument before it occurs. These safety precautions are important to the safe operation of this product and should be observed at all times.

Distinctive Displays

The following displays are used to distinguish precautions by the degree of injury or damage that may result if the precaution is ignored.



WARNING WARNING

Items indicated by this display are precautions which, if ignored, would result in serious injury.



CAUTION CAUTION

Items indicated by this display are precautions which, if ignored, may result in injury or material.

- Here “injury” refers to injuries such as cuts, burns or electric shock the treatment of which will not likely require hospitalization or long-term attention.
- “Material damage” refers to damage to facilities, buildings, acquired data, etc.

Before using this product, be sure that you have thoroughly read and understood this instruction manual to ensure proper operation. After reading this manual, be sure to keep it in a convenient place for easy reference.

This instrument complies with the protection requirement for residential and commercial areas. If this instrument is used close to industrial areas or transmitters, the equipment can be influenced by electromagnetic fields.



WARNING

- ⚠ Do not stare into the laser beam directly as this may result in damage to your eyes. W-800 is a Class IIIa (3R) Laser product.
- ⚠ Do not look into the laser radiation aperture directly as this may result in damage to your eyes.
- ⚠ Never use the telescope to view intense light such as direct sunlight or sunlight reflected through a prism as this may result in loss of sight.
- ⚠ Do not disassemble, modify or repair this product as there a risk of laser radiation.
- ⚠ Do not aim the laser beam at a person as it is harmful to the eyes and body. Receive the examination treatment by the doctor when the eyesight or body trouble is doubted by any chance.
- Electro-Magnetic Compatibility (EMC): This instrument complies with the protection requirement for residential and commercial areas. If this instrument is used close to industrial areas or transmitters, the equipment can be influenced by electromagnetic fields.
- Do not use this product in a coal mine, in a location where there is coal dust, or near flammable material as there is a risk of explosion.
- Do not disassemble, modify or repair this product as there is a risk of fire, electric shock and burn injury. If you think the product requires repair, contact the retail outlet where you purchased it or an authorized repair site.
- Only use the battery charger intended for this product as the battery charger. Use of another battery charger entails a risk of fire or burn injury from the battery bursting into flames due to possible differences in voltage or polarity.
- Do not use a damaged electric cord plug or loose electric outlet when charging as there is a risk of fire or electric shock.
- Do not charge the battery while covered by clothes or similar item as there is a risk of fire if the clothes ignite.
- Do not use the battery or charger when wet as there is a risk of fire and burn injury due to short-circuit.
- To prevent making short-circuit when removing the battery and charger from the case and storing them, apply electrically resistant tape to the poles of the battery. Storing the battery and charger as it may result in fire or burn injury due to short-circuit.
- Do not throw the battery into fire or expose it to heat as there is a risk of injury if it explodes



CAUTION

- ⚠ For your safety, perform the initial and periodical inspection as well as when the instrument is fixed and adjusted.
 - ⚠ When the laser beam enters eyes, an unexpected accident might be caused by blink of eyes. Do not place the laser product at a height where its laser beam may hit the eyes of car drivers and pedestrians.
 - ⚠ Do not place the laser product at a place where its laser beam may hit a reflecting object such as a mirror or a glass window. The reflection beam of the laser is also harmful to the human body.
 - ⚠ When not performing measurement, cut off the power supply or shade the Objective lens with Objective cap to prevent the instrument emitting the laser beam.
 - ⚠ Keep the laser product in the place where the person who does not have the product knowledge such as children does not touch by mistake.
 - ⚠ Before disposing of the instrument, destroy its power supply mechanism to prevent it from emitting the laser beam.
-
- Do not remove the handgrip without good reason. If it does come off, be sure to attach it securely to the instrument with screws. If it is not fastened securely, the instrument may fall when you grasp the handgrip, leading to possible injury.
 - Do not short the poles of the battery or charger as there is a risk of injury or fire.
 - Do not touch any fluid which may leak from the battery as there is a risk of chemical burn injury or reaction.
 - Do not insert or remove the electric plug with wet hands as there is a risk of electric shock.
 - Do not use the case to stand on as it is slippery and unstable and may cause you to fall, resulting in possible injury.
 - Be sure the tripod itself and the instrument on the tripod are both installed securely as insecure installation may cause the tripod to fall over or the instrument to drop, resulting in possible injury.
 - Do not carry the tripod with the metal shoe pointing toward another person as it may injure him/her.



- The instrument contains a rechargeable battery and a battery charger.
- It may be illegal to dispose the battery at the end of its useful life.
- Check with your local solid waste officials for details for recycling.

[Usage precautions]

Surveying instruments are high-precision instruments. In order to assure that the Electronic Total Station W-800 series product which you have purchased will provide long-lasting maximum performance, the precautions in this manual must be followed. Be sure to follow these instructions and use this product properly at all times.

[Solar observation]



WARNING WARNING

Never view the sun directly using the telescope as this may result in loss of sight. Never point the objective lens directly at the sun as this may damage internal components. When using the instrument for solar observation, be sure to attach the specially designed solar filter (MU64) to the objective lens.



[Laser beam]

Do not stare into laser beam. W-800 series is a Class IIIa (3R) Laser product.

[EDM axis]

The W-800 series EDM is the red visible laser beam and the beam diameter is very small. The beam is emitted from the objective center and the base plate center hole. The EDM axis is designed to coincide with the telescope sight axis (but both axes may deviate slightly because of intense temperature changes and a long time lapse).

[Target constant]

Confirm the Target Constant of the instrument before measurement.

If a different constant is to be used, use the correct constant of the target. The constant is stored in the instrument's memory when turned off.

[Reflectorless and reflector sheet]

Reflectorless measurement precautions:

- The measurement range and accuracy of Reflectorless are based on the condition that laser beam is emitted perpendicular to the white side of the Kodak Gray Card. There is a possibility that the range may vary when the target does not satisfy the conditions above at survey work. The measurement range may be influenced by the shape of the target and its environment.
- There is a possibility that the instrument may not be able to correctly calculate out the distance when receiving reflected laser beam from forth and back directions in case of measuring the target on the road.
- There is a possibility that measured distance may be longer or shorter than the actual one when measuring a target of slope or sphere or rugged shape as the distance is calculated out from synthesized values.

- There is a possibility that the instrument may not be able to correctly calculate out the distance when receiving reflected laser beam from a man or a car that comes and goes in front of the target.
- There is a possibility that the distance may not be correctly measured when measuring a target in the direction where there is a reflecting object (mirror, stainless board and white wall, etc.) or under too strong sun light.
- In a situation high accuracy may not be expected, perform the measurement by reflector sheet or prism.
- The measurement range at TRACK mode is over 5m.
- It may take longer time than usual when measuring the distance exceeding 300m or the distance to an object that is hard to measure.

Reflector sheet measurement precautions:

- There is a possibility that correct distance measurement may not be performed by dispersion or reduction of laser beam when the laser beam comes into the target from diagonal angle.
- When using reflector sheet, set the reflector sheet to have its surface be perpendicular to the aiming line. If it is positioned not to be perpendicular, there is a possibility that correct distance measurement may not be performed by dispersion or reduction of laser beam.

[Battery & charger]

- Do not use any batteries and battery chargers other than those PENTAX assured adequate.
- If water should happen to splash on the instrument or the battery, wipe it off immediately and allow it to dry in a dry location. Do not put the instrument in the case until it is completely dry as this may result in damage to the instrument.
- Turn off the power when removing the battery from the instrument as removing the battery while the power is still on may result in damage to the instrument.
- The battery mark displayed on the instrument is only an estimate of remaining battery power and is not completely accurate. Replace the battery quickly when it is about to run out as the time a battery lasts on one full charge differs depending on conditions of ambient temperature, and the measurement mode of the instrument.
- Confirm the battery level remaining before operating.

[Auto focus]

The Auto focus mechanism is very precise but will not function under every condition. Focusing depends on brightness, contrast, the shape and size of the target. In such a case, press the AF button and focus on the target by operating the Power focus key or the Focus ring.

[LD POINT, laser pointer]

When making a correct direction using the "LD POINT," aim the laser beam at the wall and mark the center and then confirm the discrepancy between the reticle center and the marked point beforehand.

[Interface]

Do not insert or remove SD card, CF card and USB Connector outdoors.

Be careful not to let dust, mud, sand, water, harmful gas or salty steam enter the card slot or USB connector port. Be sure to turn the instrument's power off before inserting or removing the SD card, CF card or USB Connector.

[Touch panel]

Use the Stylus pen when you touch the panel for operation of software.

Do not touch the panel with any things such as fingertips or pen point as this may scratch and damage the screen.

[Data saving]

When using application software, store data in SD card drive, CF card drive or DiskOnChip folder. Data stored in other drives is deleted when the power is turned OFF.

[Storage and operating environment]

- To prevent making short-circuit when removing the battery and charger from the case and storing them, apply electrically resistant tape to the poles of the battery. Storing the battery and charger as is may result in fire or burn injury due to short-circuit.
- Avoid storing the instrument in places subject to extreme high, low or radically fluctuating temperature. (Ambient temperature range during use: -20°C to $+50^{\circ}\text{C}$)
- Distance measurements may take longer when atmospheric conditions are poor such as when heat shimmer is present. When storing the instrument, always put it in its case and avoid storage in dusty location or location subject to vibration or extreme heat or humidity.
- Whenever there is a sharp temperature difference between the instrument's storage and usage environment, allow the instrument to adjust to the environment for an hour or more before using it. Be sure to protect the instrument from the sun if the location is subject to intense direct sunlight.
- During surveys for which the survey precision or atmospheric measurement method has been defined measure the atmospheric temperature and pressure separately and enter those values rather than using the Automatic Atmospheric Correction function.
- The battery should be charged approximately once per month if the instrument is to be stored for an extended period of time. The instrument should also be removed from its case occasionally and aired out.
- In addition to these precautions, be sure to handle the instrument properly at all times following the descriptions given in the various sections of this manual to assure safe and proper measurements.

[Transporting and carrying the instrument]

- Be careful to protect this instrument from shock of impact and excessive vibration which may result in damage during transportation and shipment.
- When transporting the instrument, always put it in the case and wrap shockabsorbing material around it and be sure it is handled as "FRAGILE".

[Checks and repairs]

- Always check the instrument before beginning work and check that the instrument is maintaining the proper level of precision. Pentax bears absolutely no responsibility for damages due to survey results obtained from surveys conducted without an initial instrument check. Never disassemble the instrument, battery or charger even if you do detect an abnormality as there is a risk of fire or electric shock due to short-circuit. If you think the product requires repair , contact the retail outlet where you purchased it or an authorized repair site.
- Never disassemble the instrument, battery or charger even if you do detect an abnormality as there is a there is a risk of fire or electric shock due to short-circuit, If you think the product requires repair, contact the retail outlet where you purchased it or an authorized repair site.

CONTENTS

PRECAUTIONS REGARDING SAFETY	1
SAFETY PRECAUTIONS(MUST BE FOLLOWED)	1
USAGE PRECAUTIONS	4
1. BEFORE USING THE INSTRUMENT	9
1.1 NAMES OF PARTS	9
1.2 ATTACHING AND CHARGING THE BATTERY	10
1.3 INSERTING/ REMOVING SD CARD	11
1.4 INSERTING/ REMOVING CF CARD	12
1.5 CONNECTING USB CABLE	13
2. DISPLAY AND KEYBOARD	14
2.1 DISPLAY AND KEYBOARD	14
2.2 OPERATION KEYS	14
2.3 ALPHANUMERIC INPUT	15
2.4 LASER PLUMMET, LASER POINTER	15
3. PREPARATION FOR SURVEYING	16
4. SPECIFICATIONS	19
5. NOTICE TO THE USER OF THIS PRODUCT	21

1. BEFORE USING THE INSTRUMENT

1.1 Names of parts

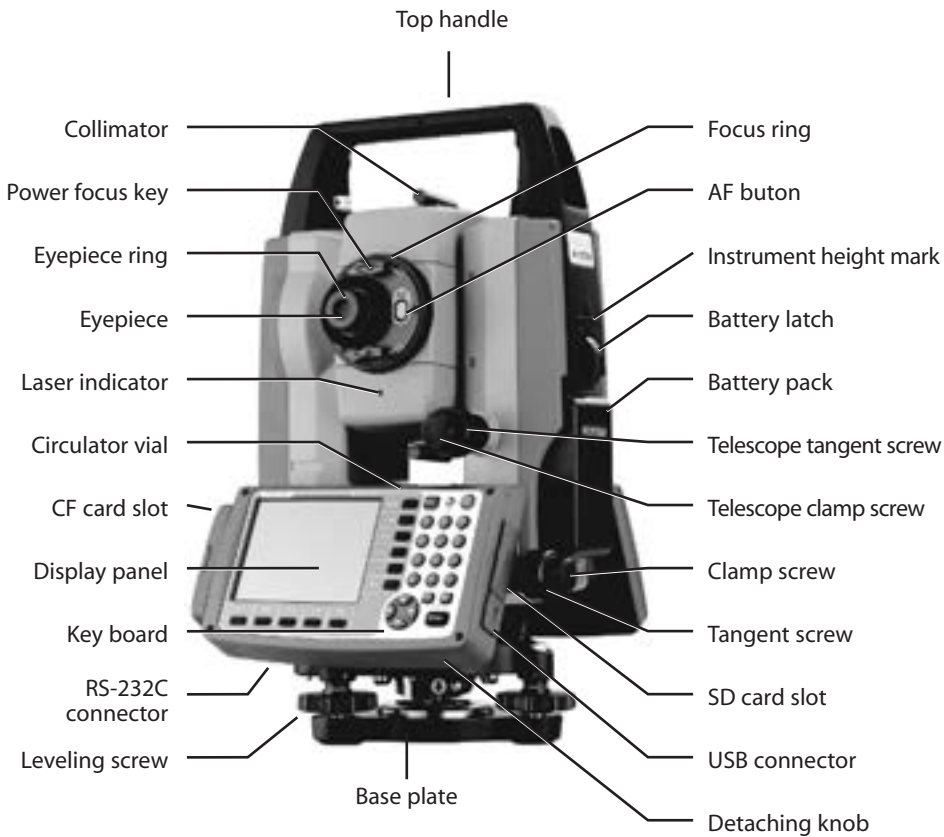

Objective lens



A shift fixed screw is attached to Base plate of a shift base type model.

1.2 Attaching and charging the battery

[Removing the Battery]

- Å Turn the Battery latch anticlockwise and remove the battery pack.
 - Ç Lift up the battery pack and remove it from the instrument.
- Be absolutely sure to turn the power off when removing the battery pack as removing the battery pack while the power is still on may result in damage to the instrument.



[Attaching the battery]

- Å Align the guide grooves on the battery pack with the guide grooves on the instrument and push the top of the battery pack into place.
- Ç Turn the Battery latch clockwise to fix.



- Turn and fix the Battery latch to lock the battery pack while in use

1.3 Inserting / removing SD card

- Be sure to turn the instrument's power off before inserting or removing the SD card.

[Inserting SD card]

- 1) Open the Slot cover
- 2) Insert the SD card into the slot. (The side with terminal should face the instrument and the cut-off corner should be up).
- 3) Insert the SD card to the end. Be sure not to press the card too hard.
After the SD card is inserted, close the Slot cover completely.



[Removing SD card]

- 1) Open the Slot cover
- 2) Lightly press the SD card so the card pops out.
- 3) After the SD card is removed, close the Slot cover completely.



- Do not open/close the Slot cover or insert/remove the SD card outdoors.

1.4 Inserting / removing CF card

- Be sure to turn the instrument's power off before inserting or removing the CF card.

[Inserting CF card]

- 1) Unlock the CF card slot cover by pressing 'CF OPEN' button, then, open the cover.
- 2) Carefully insert the CF card into the Slot until the Inject button pops out.
(The side with terminal must face the instrument)
- 3) After the CF card is inserted, close the Slot cover completely.

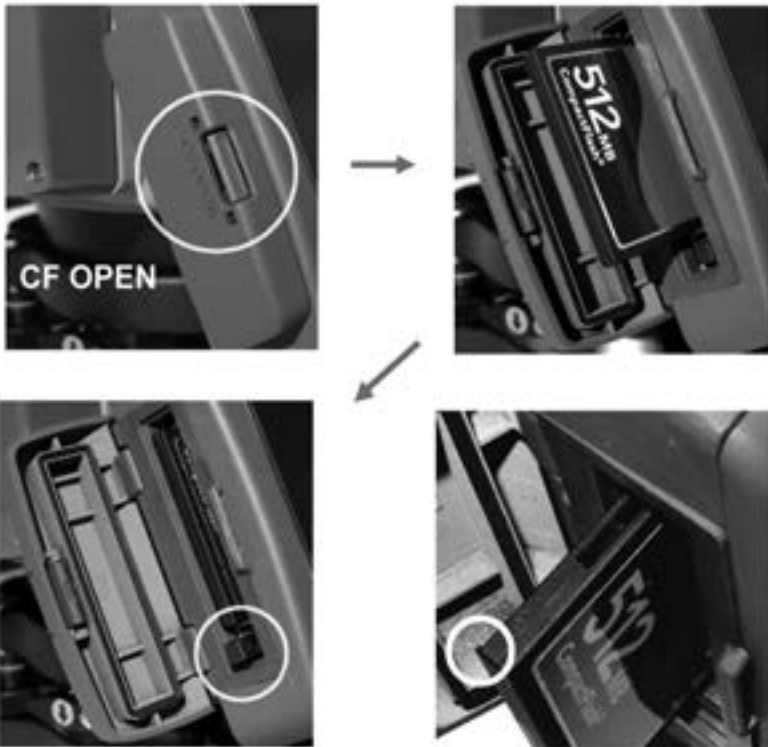

Insert the CF card with its tub facing the instrument.

- Do not open/close the Slot cover or insert/remove the CF card outdoors.

[Removing CF card]

- 1) Unlock the CF card slot cover by pressing 'CF OPEN' button, then, open the cover.
- 2) Press the Inject button so the CF card pops out.
- 3) After the CF card is removed, close the Slot cover completely.



1.5 Connecting USB cable

- Be sure to turn the instrument's power off before connecting or disconnecting the USB Cable.
- 1) Open the USB connector cover
 - 2) Insert the USB connector into the USB port in right direction.
 - 3) After the USB is disconnected, close the USB connector cover completely.



Be sure the direction of USB mini B connector is same as that of the USB port.

- Do not open/close the USB connector cover or connect/disconnect the USB cable outdoors.

2. DISPLAY AND KEYBOARD

2.1 Display and keyboard

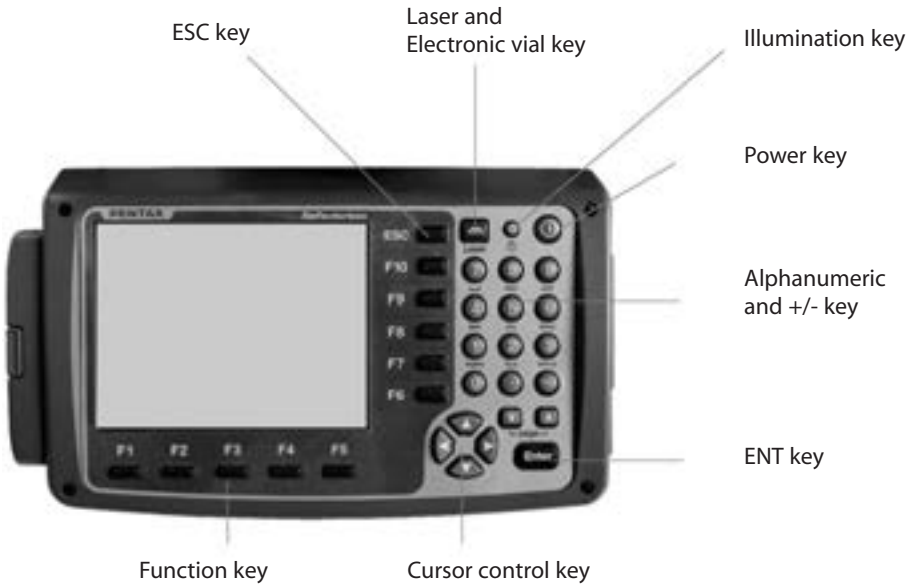

2.2 Operation keys

Key	Description	
	Used to turn ON/OFF of power supply	
	Used to return to previous screen or cancels an operation.	
	Used to turn ON/OFF the illumination of the LCD display.	
	Used to accept the selected (highlighted) choice or the displayed screen.	
[LASER]	Used to operate the functions such as Laser plummet and the LD point screen	
[Alphanumeric]	Used to input alphabets and numerical value.	
		Used to display the data 1 page back or 1 page ahead
		Used to move the cursor up or down
		Used to move the cursor left or right

2.3 Alphanumeric input

The point name is inputted by the Alphanumeric keys as following.

Key	Letter under Key	Letter & Figure order to input
[0]		[@] [.] [_] [-] [:] [/] [0]
[1]	PQRS	[P] [Q] [R] [S] [p] [q] [r] [s] [1]
[2]	TUV	[T] [U] [V] [t] [u] [v] [2]
[3]	WXYZ	[W] [X] [Y] [Z] [w] [x] [y] [z] [3]
[4]	GHI	[G] [H] [I] [g] [h] [i] [4]
[5]	JKL	[J] [K] [L] [j] [k] [l] [5]
[6]	MNO	[M] [N] [O] [m] [n] [o] [6]
[7]		[] [?] [!] [_] [^] [&] [7]
[8]	ABC	[A] [B] [C] [a] [b] [c] [8]
[9]	DEF	[D] [E] [F] [d] [e] [f] [9]
[.]		[.] [,] [:] [;] [#] [()]
[+/-]		[+] [-] [*] [/] [%] [=] [<] [>]

2.4 LD POINT, Laser pointer

How to activate/terminate the laser beam emission differs depending on application software. For exact method of activating/terminating laser beam emission, refer to the instructions in the manuals of respective software.

- The Laser indicator is turned on and the  mark on the left of the screen blinks while the Laser pointer function is operating.
- The beam of the sun is strong and visual confirmation is difficult in daytime when outdoors.
- The laser beam is designed not to be able to observe through the telescope.
- Please visually align the laser beam to the target and mark the center. Confirm the alignment (horizontal and vertical) before measuring when performing accurate work like stake out when using the Laser pointer function.
- Please do not look at the laser source of beam directly.

3. PREPARATION FOR SURVEYING

[Auto focus: Target sighting by Normal mode]

- Å Loosen the telescope clamp and horizontal clamp screws.
- Ç Point the telescope at the target using a collimator.
- È Tighten the above two screws.
- Ë Adjust the eyepiece.
- Ó Look through the telescope and press the AF button. Move your eye vertically and horizontally to see if the target image moves in relation to reticle.
- Ū Align the reticle accurately on the target using telescope and horizontal tangent screws.

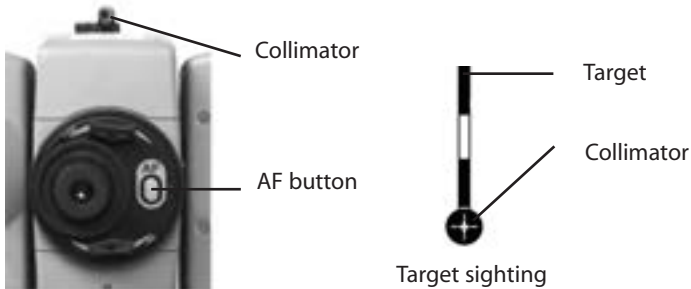

[Auto focus: Target sighting by Continuous mode]

- Å Loosen the telescope clamp and horizontal clamp screws.
- Ç Point the telescope at the target using a collimator.
- È Tighten the above two screws.
- Ë Adjust the eyepiece.
- Ó Look through the telescope and then press the AF button for two seconds to beep, and release the key to enter into the Continuous mode.
- Ū Align the reticle accurately on the target using telescope and horizontal tangent screws.
- a Point the telescope to the next target as well.

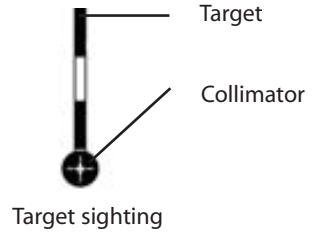
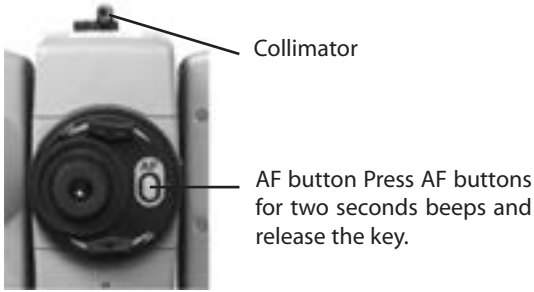

[Auto focus: Target sighting by Power focus mode]

- Å Loosen the telescope clamp and horizontal clamp screws.
- Ç Point the telescope at the target using a collimator.
- È Tighten the above two screws
- Ñ Adjust the eyepiece.
- Ó Look through the telescope, and then operate the Power focus key and focus on the target.
- Ù rately on the target using telescope and horizontal target screws.

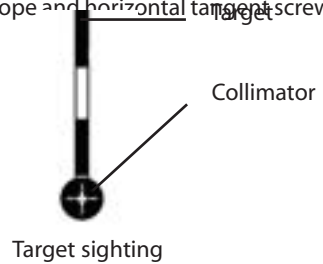
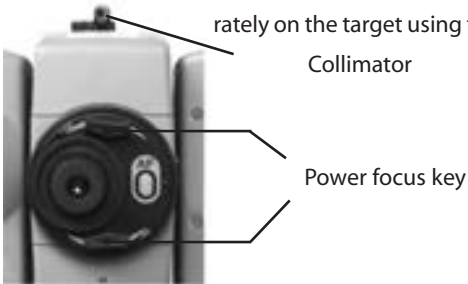

[Target sighting by manual focus]

- Å Loosen the telescope clamp and horizontal clamp screws.
- Ç Point the telescope at the target using a collimator.
- È Tighten the above two screws.
- Ñ Adjust the eyepiece.

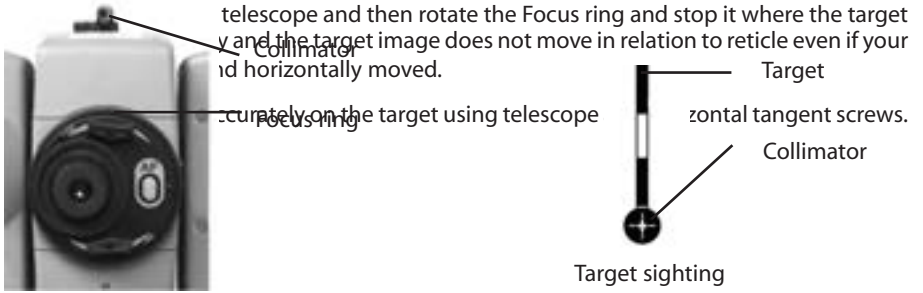

- The Focus ring rotation “clockwise” makes it possible to focus on closer objects and “counter clock wise” will focus on further objects.

4. SPECIFICATIONS

Model		W-821NX	W-822NX	W-823NX	W-825NX	W-835NX
Telescope	Magnification	30x				
	Effective aperture	45mm (EDM 45mm)				
	Resolving power	3.0"				
	Field of view	2.6% (1°30')				
	Minimum focus	1.0 m				
	Focus	Auto focus / Power focus / Manual				
Distance measurement	Laser class	Visible Laser: Class IIIa (3R) (Reflectorless)/ Class II (2) (Prism, sheet)				
Measurement range (Good condition) ③	Reflectorless ①	1.5 ~ 550m				
	Reflector sheet ②	1.5 ~ 600m (800m)				
	Mini Prism	1.5 ~ 2500m (3000m)				
	1P	1.5 ~ 7000m (9000m)				
	3P	1.5 ~ 9000m (9999m)				
	Accuracy ④	Prism / Reflector Sheet	1.5m ~ 10m: ± (3+2ppm x D)mm 10m ~ : ± (2+2ppm x D)mm			
Reflectorless		1.5m ~ 300m: ± (5+2ppm x D)mm 300m ~ : ± (7+10ppm x D)mm				
At Auto-ATM. Correction	Prism / Reflector Sheet	1.5m ~ 10m: ± (3+10ppm x D)mm 10m ~ : ± (2+10ppm x D)mm				
	Reflectorless	1.5m ~ 300m: ± (5+10ppm x D)mm 300m ~ : ± (7+18ppm x D)mm				
	Minimum count	0.1mm (Fine mode), 1mm (Normal mode), 10mm (Track mode)				
Measurement time ⑤	Repeat meas.	Normal (1mm):	Prism / Ref.sheet 2.0sec. Ref.less 2.0sec.			
		Quick (1mm):	Prism / Ref.sheet 1.2sec. ⑥			
		Track (10mm):	Prism / Ref.sheet 0.4sec. Ref.less 0.4sec.			
	Initial meas.	Normal (1mm):	Prism / Ref.sheet 2.5sec. Ref.less 2.4sec.			
		Quick (1mm):	Prism / Ref.sheet 1.7sec. ⑥			
		Track (10mm):	Prism / Ref.sheet 2.5sec. Ref.less 2.5sec.			
Angle measurement	Measuring method	Absolute rotary encoder				
	Detection method	Vertical / Horizontal angle: 2 sides				
	Minimum count	1" / 5" selectable				
	Accuracy (ISO 17123-3)	1"	2"	3"	5"	
Compensator		3 axis ⑦			2 axis	
Tangent screw		2 speed			1 speed	
Sensitivity of vials	Plate level (electronic)	30"/div.				
	Circular level	8'/2mm				
Plummet		Visible Laser, ±0.5mm (instrument height 1.5m)				
Base		Detachable			Shifting	
	Dust and Water Protection	IP54 (instrument only)				
Ambient temperature		-20°C ~ 50°C / -4°F ~ 122°F (Working range)				
Tripod thread		5/8" x 11			35mm P2	
Dimensions / Weight	Dimension	197(W) x 347 (H) x 217 (L)mm				
	Weight (incl. Battery)	6.3 kg			6.2 kg	
	Carrying case	380(W) x 292 (H) x 475 (L)mm / 3.2 kg				
Battery pack BP02	Power source	Ni-MH 4300mAh (Rechargeable), DC6.0V				
	Operation time	Approx. 7 hours (single measurement every 30 seconds)				
	Weight	380g				
Battery charger BC03 and AC Adapter AC01	Input voltage (AC01)	AC 100 ~ 240V				
	Output voltage (BC03)	DC7.5V				
	Weight	280g				

Model		W-821NX	W-822NX	W-823NX	W-825NX	W-835NX
Data Process	CPU, Clock frequency	Intel® XScale, 400MHZ				
	OS	Microsoft® Windows® CE.NET 4.2				
	Application software	Selectable				
	Internal memory	SDRAM = 64MB FLASH = 128MB (built-in)				
	Memory card	2GB (Max) ⑨				
	I/F	RS-232C , CF Type II , SD CARD , USB				
Display / Keyboard	Display type	3.7 inch, Color LCD, 640x480 pixels ⑨ with back light and touch panel function				
	Quantity	2	1 (2nd optional)			
	Keys	33 each(12 numeric / 11 function / 10 special)				
	Display back light	Intensity settings: 10 steps				
	Laser Pointer	Yes				
Date clock	Yes					

[Note]

- ① The measurement range and accuracy of reflectorless, and time required to measure may vary by the shape, size of surface area and reflection rate of the target and its environment. The measurement range of reflectorless is determined by the white side of the Kodak Gray Card.
- ② Reflector sheet: PENTAX genuine Reflector sheet
- ③ The measurement range may vary by conditions of the environment.
Normal conditions: 20km visibility with slight shimmer
Good conditions: 40km visibility, overcast, no heat, no shimmer and moderate wind.
- ④ When automatic atmospheric correction is on, the EDM error is 10ppm in prism and reflector sheet mode.
- ⑤ EDM measuring time is determined in good conditions. It may takes longer than usual to measure the distance exceeding 4000m in prism mode and 300m in reflectorless mode.
- ⑥ Quick mode, which functions with prism and reflector sheet, is effective only under normal mode(1mm) and up to 500m.
- ⑦ In addition to dual-axis correction in the (X) and (Y) direction, mechanical error in the instrument is corrected.
- ⑧ Memory card is not supplied with the instrument.
- ⑨ Depending on application software.

Remarks: The brand names mentioned in the specifications are a trademark or a registered trademark of each company.

5. NOTICE TO THE USER OF THIS PRODUCT

To assure compliance with the Safety standard 21 CFR, Chapter 1. Subchapter J.
The U.S. bureau of Radiological Health requires the following information to be provided to user:



It can be dangerous to look into the beam with optical equipment such as binoculars and telescopes.

1) Specifications of Laser Radiation

- A) The EDM module of the W-800 series produces a visible light beam, which is emitted from the telescope objective lens and the center hole of the instrument base plate. The W-800 series is designed and built to have a laser diode radiating at 620-690 nm.
- B) Radiant power
The W-800 series is designed and built to radiate a maximum average radiant power of 4.75mW from the telescope, and 0.95mw from the center hole of the base plate. The user may be subject to this radiation as a beam while operation until such time that the instrument is turned off.

2) The following labels are affixed to and must remain attached to this laser product.

- A) The following Certification label is located near the Plate level:
"This laser product is complied with the provisions of 21 CFR 1040. 10 and 1040.11. For a Class IIIa (3R) laser product."
- B) Caution label is located near the exit aperture:
"AVOID EXPOSURE Laser radiation is emitted from this aperture."
- C) Warning logotype is located on the surface of the telescope:
"DANGER LASER RADIATION AVOID DIRECT EYE EXPOSURE"
- D) Warning label is Located near the exit aperture.

3) Caution to maintain the safety in compliance with the standard

- A) To maintain the safety standard, refrain from any operation, maintenance, or adjustment other than described in this instruction manual.
- B) Operation, maintenance or adjustment other than those specified in this instruction manual may result in hazardous radiation exposure.
- C) Maintenance and repair not covered in this manual must be done by an authorized Pentax dealer.
- D) How to activate/terminate the laser beam emission differs depending on application software. For exact method of activating/terminating the following types of laser beam emission, refer to the instructions in the manuals of respective software.
 - 1) Laser beam emission by the Distance measurement
 - 2) Laser beam emission by the Laser pointer
 - 3) Laser beam emission by the Laser plummet

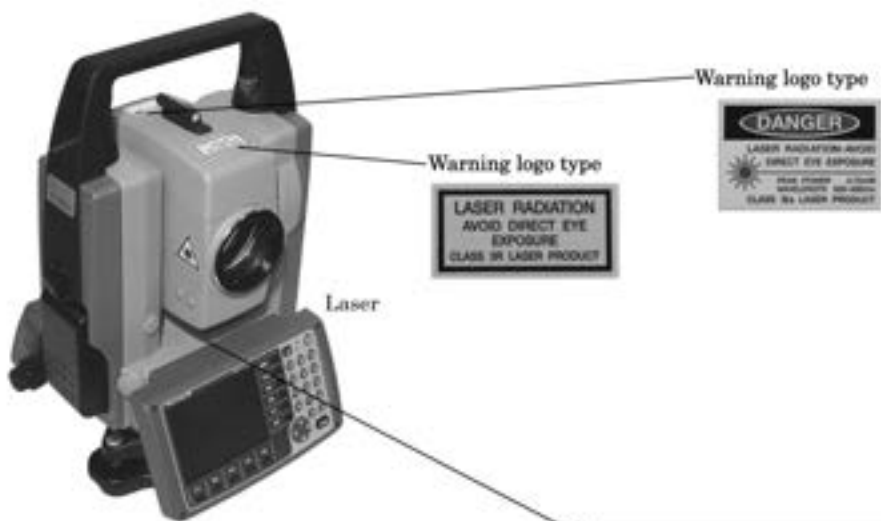
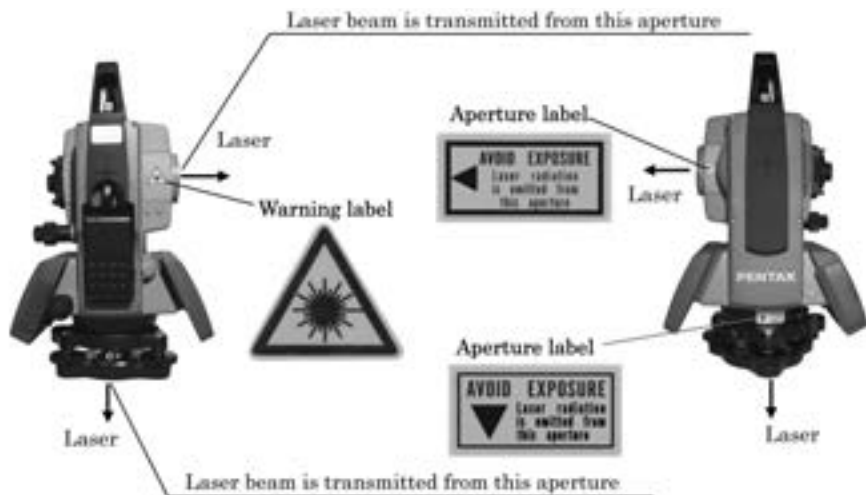

LED is turned on at the time of emission

TI Asahi Co., Ltd.

200, Kikusawa, Ogasawara-cho, Higashi-Gun, Sakai, 595-0216, Japan
 This laser product is compliant with the provisions of 21
 CFR 1040.10 and 1040.11 for a class IIIa laser product.
 ASSEMBLED by TI PENTAX (Shanghai) Co., Ltd.



TI Asahi Co., Ltd.
International Sales Department
4-3-4 Ueno Iwatsuki-Ku, Saitama-Shi
Saitama, 339-0073 Japan
Tel.: +81-48-793-0118
Fax. +81-48-793-0128
E-mail: International@tiasahi.com
www.pentaxsurveying.com/en/

Printed in Belgium



JSIMA
Japan Surveying Instruments Manufacturers' Association
*Member symbol of the Japan Surveying
Instruments Manufacturers'
Association representing the high quality
surveying products.*

PENTAX

Copyright © 2013 TI Asahi Co., Ltd. All rights reserved
The duplication, reuse or sale of any information provided on this manual including but not limited to images, is strictly prohibited without expressed permission from the copyright owners.